



LEOPARD IMAGING INC

LI-XAVIER-KIT-IMX477CS-X Data Sheet

Key Features

- Compatible with Nvidia® Jetson AGX Xavier™ Developer Kit
- MIPI CSI-2 interface
- Supports up to six cameras
- Two adapter board options
 - LI-JXAV-MIPI-ADPT-4CAM
 - LI-JXAV-MIPI-ADPT-6CAM-FP
- Sony Diagonal 7.857 mm (Type 1/2.3) CMOS Image Sensor IMX477
- Active pixels: 4056 (H) x 3040 (V)
- Color camera
- Length of the I-PEX cable: 300 mm
- Supports multiple length cables
- Connector Part#: 20525-030E-02C
- Allows customization
- Part#:
 - (1 cam) [LI-XAVIER-KIT-IMX477CS](#)
 - (2 cam) [LI-XAVIER-KIT-IMX477CS-D](#)
 - (3 cam) [LI-XAVIER-KIT-IMX477CS-T](#)
 - (4 cam) [LI-XAVIER-KIT-IMX477CS-Q](#)
 - (6 cam) [LI-XAVIER-KIT-IMX477CS-H](#)

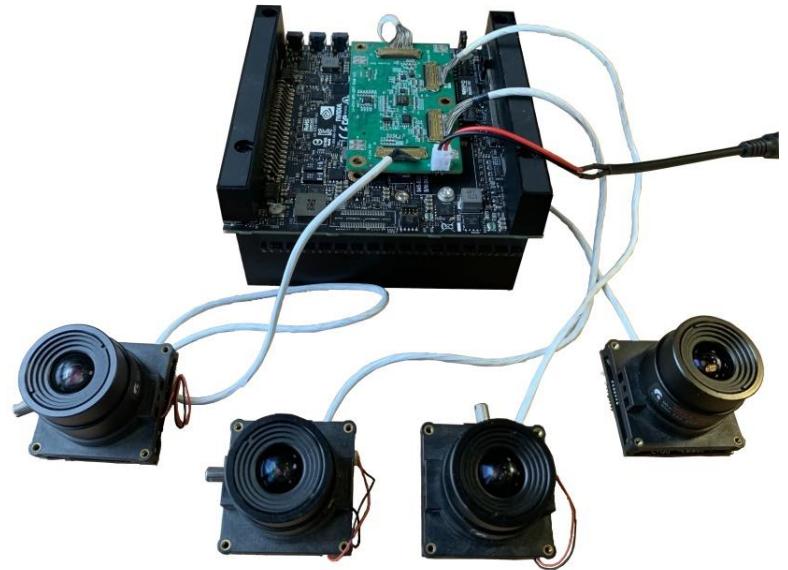

Lens Spec

- Model: ES0522F.IR
- Focal Length: 5.0 mm
- Aperture, F/#: 2.2
- FOV (D / H/ V): 96.5° / 80° / 61.5°
- TV Distortion: < -8%
- Mount Type: CS

Applications

- Industrial Applications
- Intelligent Transportation System (ITS) Cameras

BOM

Nvidia AGX Xavier Developer Kit not included

#	Items	QTY
1	LI-JXAV-MIPI-ADPT-4CAM or LI-JXAV-MIPI-ADPT-6CAM-FP	1
2	LI-IMX477-MIPI-CS	1, 2, 3, 4 or 6
3	FAW-1233-03 cable	1, 2, 3, 4 or 6



Leopard Imaging Inc.

48820 Kato Rd, Suite 100B, Fremont, CA 94538, USA
 Phone: +1-408-263-0988
 Fax: +1-408-217-1960
 Email: sales@leopardimaging.com
 Website: www.leopardimaging.com

LI-XAVIER-KIT-IMX477CS

BOM

#	Items	QTY
1	LI-JXAV-MIPI-ADPT-4CAM	1
2	LI-IMX477-MIPI-CS	1
3	FAW-1233-03 cable	1



LI-XAVIER-KIT-IMX477CS-D

BOM

#	Items	QTY
1	LI-JXAV-MIPI-ADPT-4CAM	1
2	LI-IMX477-MIPI-CS	2
3	FAW-1233-03 cable	2



LI-XAVIER-KIT-IMX477CS-T

BOM

#	Items	QTY
1	LI-JXAV-MIPI-ADPT-4CAM	1
2	LI-IMX477-MIPI-CS	3
3	FAW-1233-03 cable	3

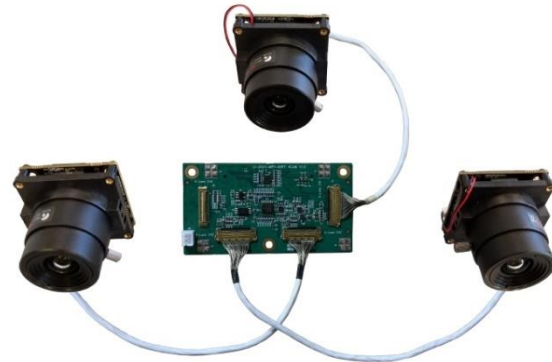

LI-XAVIER-KIT-IMX477CS-Q

BOM

#	Items	QTY
1	LI-JXAV-MIPI-ADPT-4CAM	1
2	LI-IMX477-MIPI-CS	4
3	FAW-1233-03 cable	4

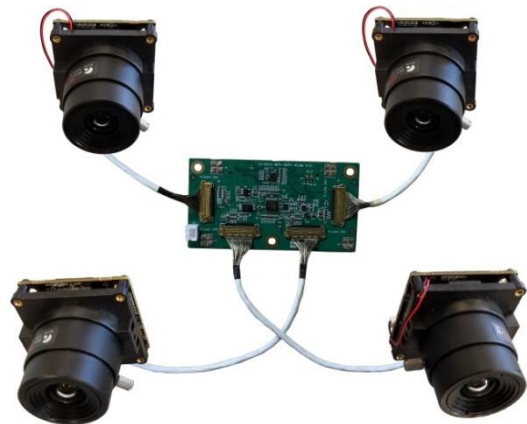

Leopard Imaging Inc.

48820 Kato Rd, Suite 100B, Fremont, CA 94538, USA
Phone: +1-408-263-0988
Fax: +1-408-217-1960
Email: sales@leopardimaging.com
Website: www.leopardimaging.com

LI-XAVIER-KIT-IMX477CS-H

BOM

#	Items	QTY
1	LI-JXAV-MIPI-ADPT-6CAM-FP	1
2	LI-IMX477-MIPI-CS	6
3	FAW-1233-03 cable	6

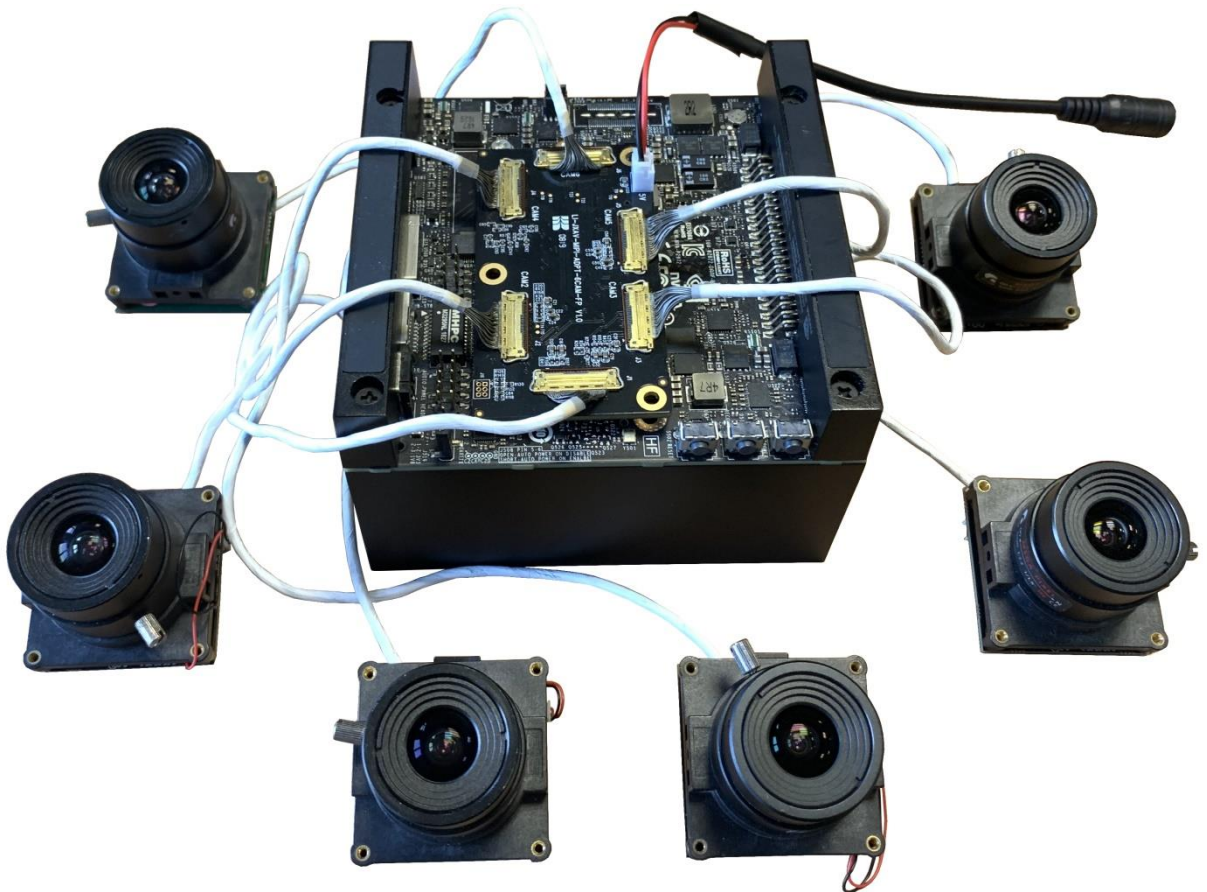
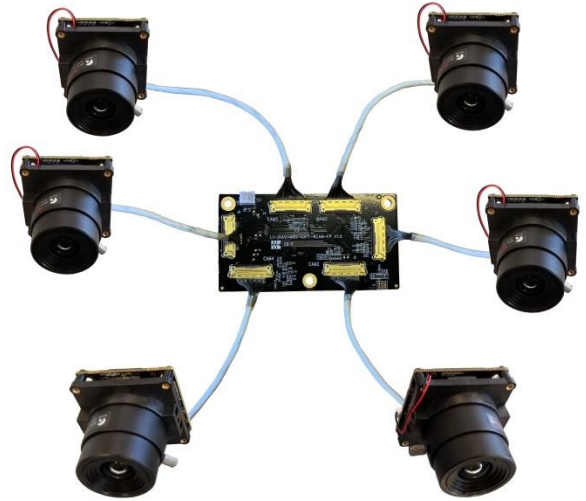

Leopard Imaging Inc.

48820 Kato Rd, Suite 100B, Fremont, CA 94538, USA
Phone: +1-408-263-0988
Fax: +1-408-217-1960
Email: sales@leopardimaging.com
Website: www.leopardimaging.com

Dimensions

LI-IMX477-MIPI-CS

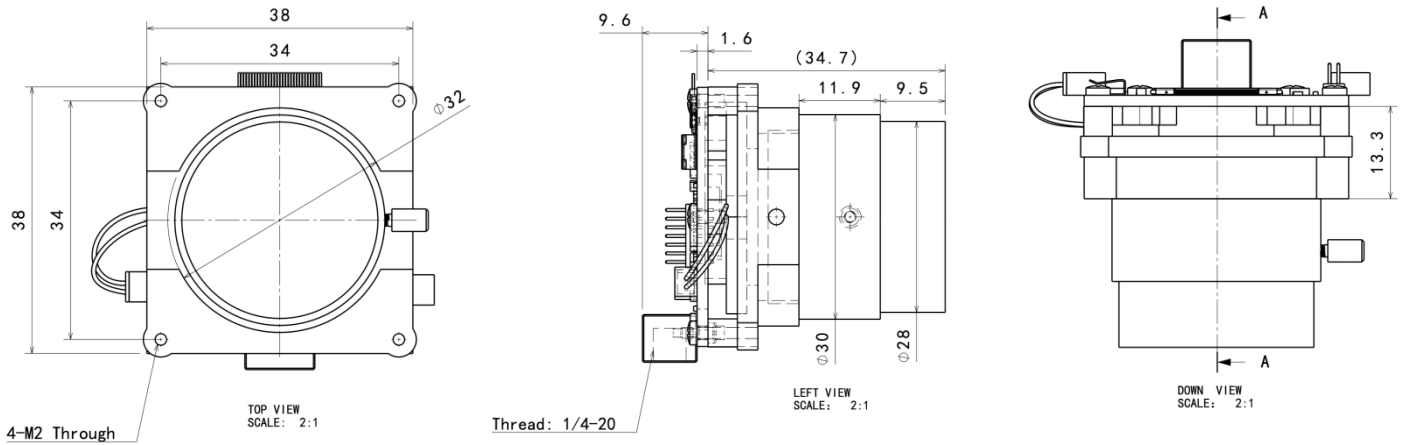

LI-JXAV-MIPI-ADPT-4CAM

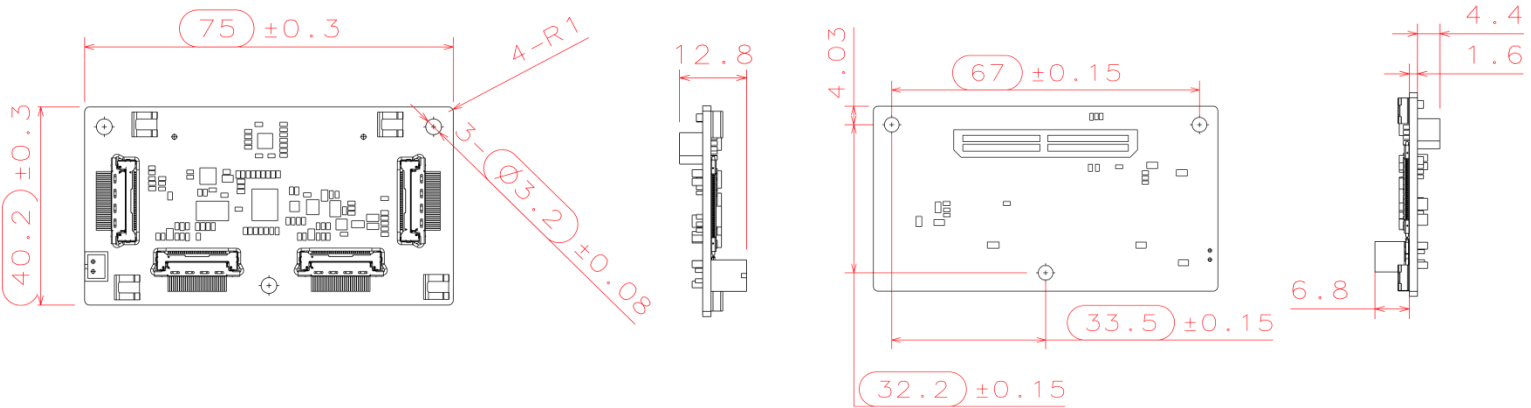

FAW-1233-03

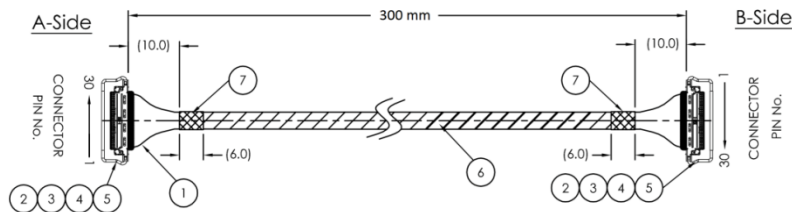

Leopard Imaging Inc.

48820 Kato Rd, Suite 100B, Fremont, CA 94538, USA
 Phone: +1-408-263-0988
 Fax: +1-408-217-1960
 Email: sales@leopardimaging.com
 Website: www.leopardimaging.com

LI-JXAV-MIPI-ADPT-4CAM

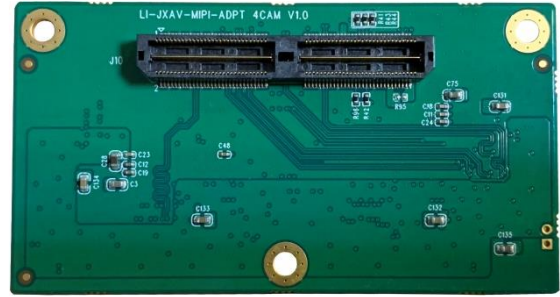

Interfaces

Interface J1

- Part#: 20525-030E-02C
- Number of Positions: 30
- Pitch: 0.4 mm
- Mating I-PEX cable: FAW-1233-03 (300 mm)

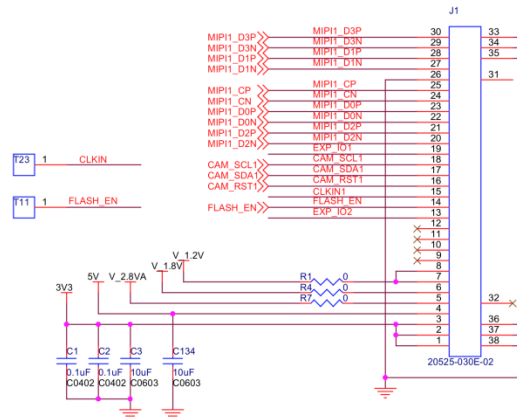

Interface J2

- Part#: 20525-030E-02C
- Number of Positions: 30
- Pitch: 0.4 mm
- Mating I-PEX cable: FAW-1233-03 (300 mm)

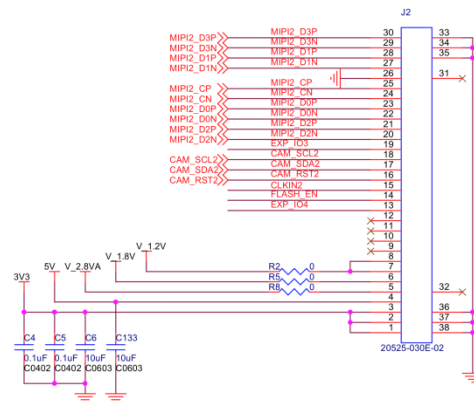

Interface J3

- Part#: 20525-030E-02C
- Number of Positions: 30
- Pitch: 0.4 mm
- Mating I-PEX cable: FAW-1233-03 (300 mm)

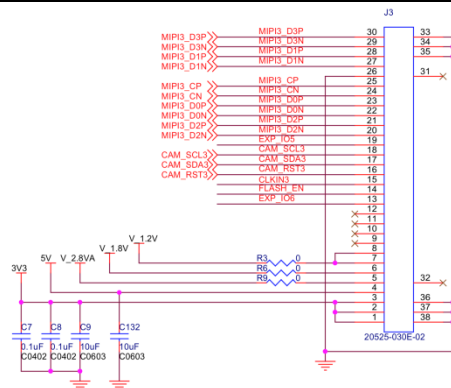

Leopard Imaging Inc.

48820 Kato Rd, Suite 100B, Fremont, CA 94538, USA
 Phone: +1-408-263-0988
 Fax: +1-408-217-1960
 Email: sales@leopardimaging.com
 Website: www.leopardimaging.com

Interface J4

- Part#: 20525-030E-02C
- Number of Positions: 30
- Pitch: 0.4 mm
- Mating I-PEX cable: FAW-1233-03 (300 mm)

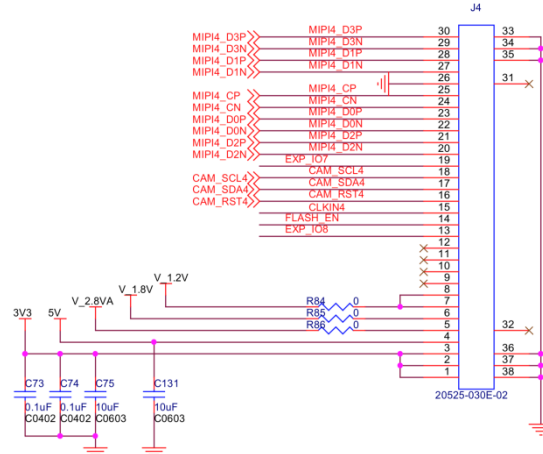

Interface J5

- Part#: 0894000220
- Number of Positions: 2
- Pitch: 2 mm

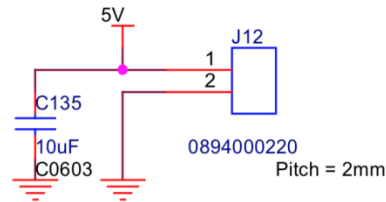

Interface J10

- Part#: QTH-060-01-L-D-A
- Number of Positions: 120
- Number of Rows: 2
- Pitch: 0.5 mm

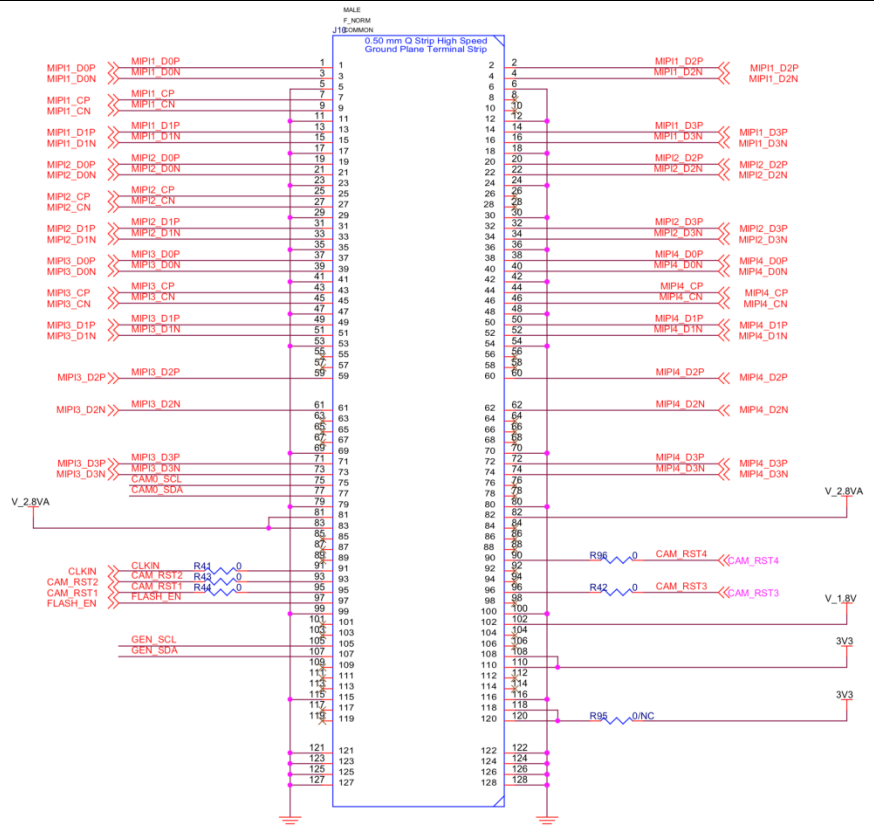

Leopard Imaging Inc.

48820 Kato Rd, Suite 100B, Fremont, CA 94538, USA
 Phone: +1-408-263-0988
 Fax: +1-408-217-1960
 Email: sales@leopardimaging.com
 Website: www.leopardimaging.com

LI-JXAV-MIPI-ADPT-6CAM-FP

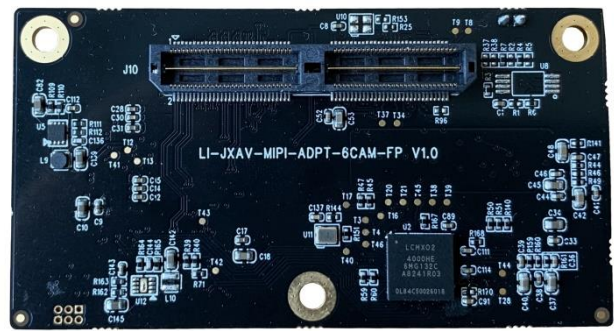
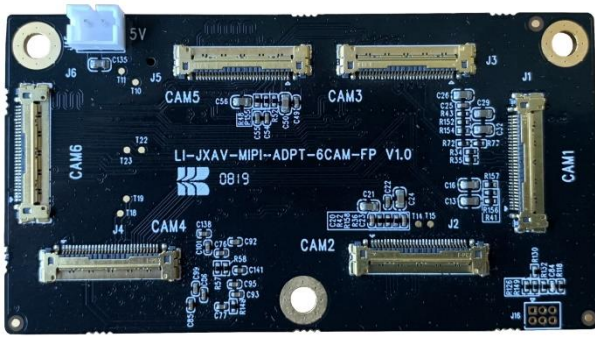

Interfaces

Interface J1 (Camera Channel 1)

- Part#: 20525-030E-02C
- Number of Positions: 30
- Pitch: 0.4 mm
- Mating I-PEX cable: FAW-1233-xx

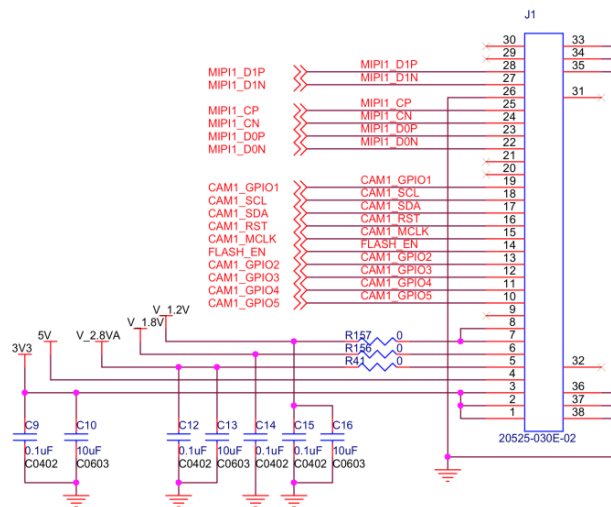

Interface J2 (Camera Channel 2)

- Part#: 20525-030E-02C
- Number of Positions: 30
- Pitch: 0.4 mm
- Mating I-PEX cable: FAW-1233-xx

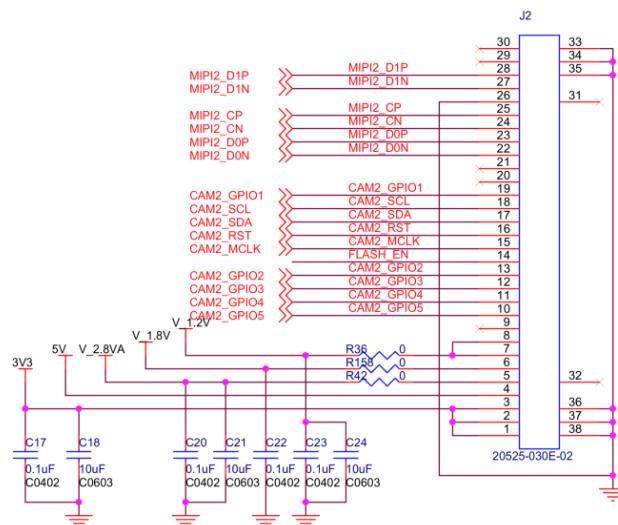

Leopard Imaging Inc.

48820 Kato Rd, Suite 100B, Fremont, CA 94538, USA
 Phone: +1-408-263-0988
 Fax: +1-408-217-1960
 Email: sales@leopardimaging.com
 Website: www.leopardimaging.com

Interface J3 (Camera Channel 3)

- Part#: 20525-030E-02C
- Number of Positions: 30
- Pitch: 0.4 mm
- Mating I-PEX cable: FAW-1233-xx

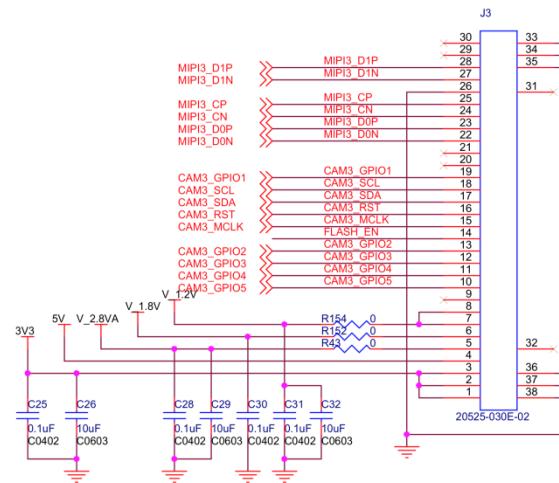

Interface J4 (Camera Channel 4)

- Part#: 20525-030E-02C
- Number of Positions: 30
- Pitch: 0.4 mm
- Mating I-PEX cable: FAW-1233-xx

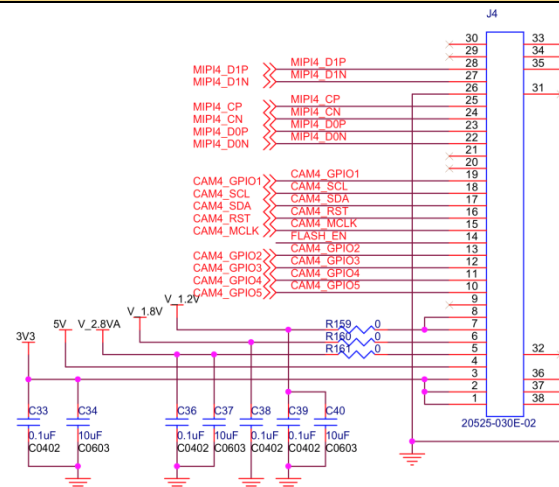

Interface J5 (Camera Channel 5)

- Part#: 20525-030E-02C
- Number of Positions: 30
- Pitch: 0.4 mm
- Mating I-PEX cable: FAW-1233-xx

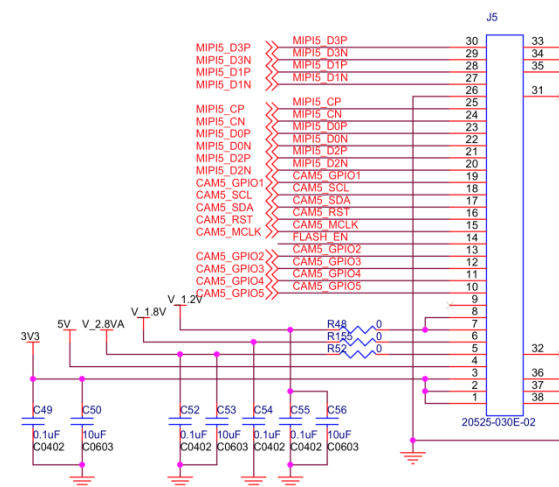

Leopard Imaging Inc.

48820 Kato Rd, Suite 100B, Fremont, CA 94538, USA
 Phone: +1-408-263-0988
 Fax: +1-408-217-1960
 Email: sales@leopardimaging.com
 Website: www.leopardimaging.com

Interface J6 (Camera Channel 6)

- Part#: 20525-030E-02C
- Number of Positions: 30
- Pitch: 0.4 mm
- Mating I-PEX cable: FAW-1233-xx

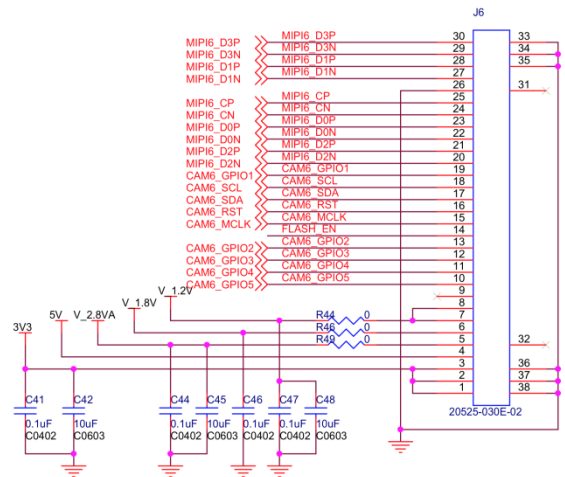

Interface J16 (FPGA Programming Interface)

- Part#: 20021311-00006T4LF
- Number of Positions: 6
- Pitch: 0.050" (1.27 mm)
- Number of Rows: 2

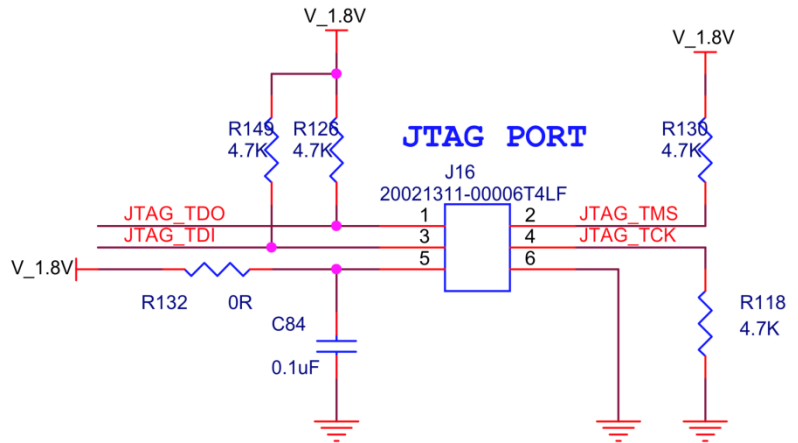

Interface J15 (External Power Input Interface)

- Part#: 0894000220
- Number of Positions: 2
- Pitch: 2 mm

External Input Power

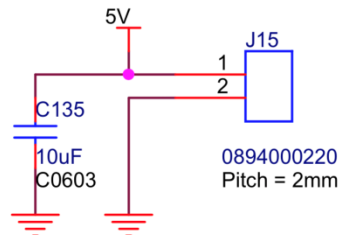

Interface J10 (To Xavier)

- Part#: QTH-060-01-L-D-A
- Number of Positions: 120
- Number of Rows: 2
- Pitch: 0.5 mm

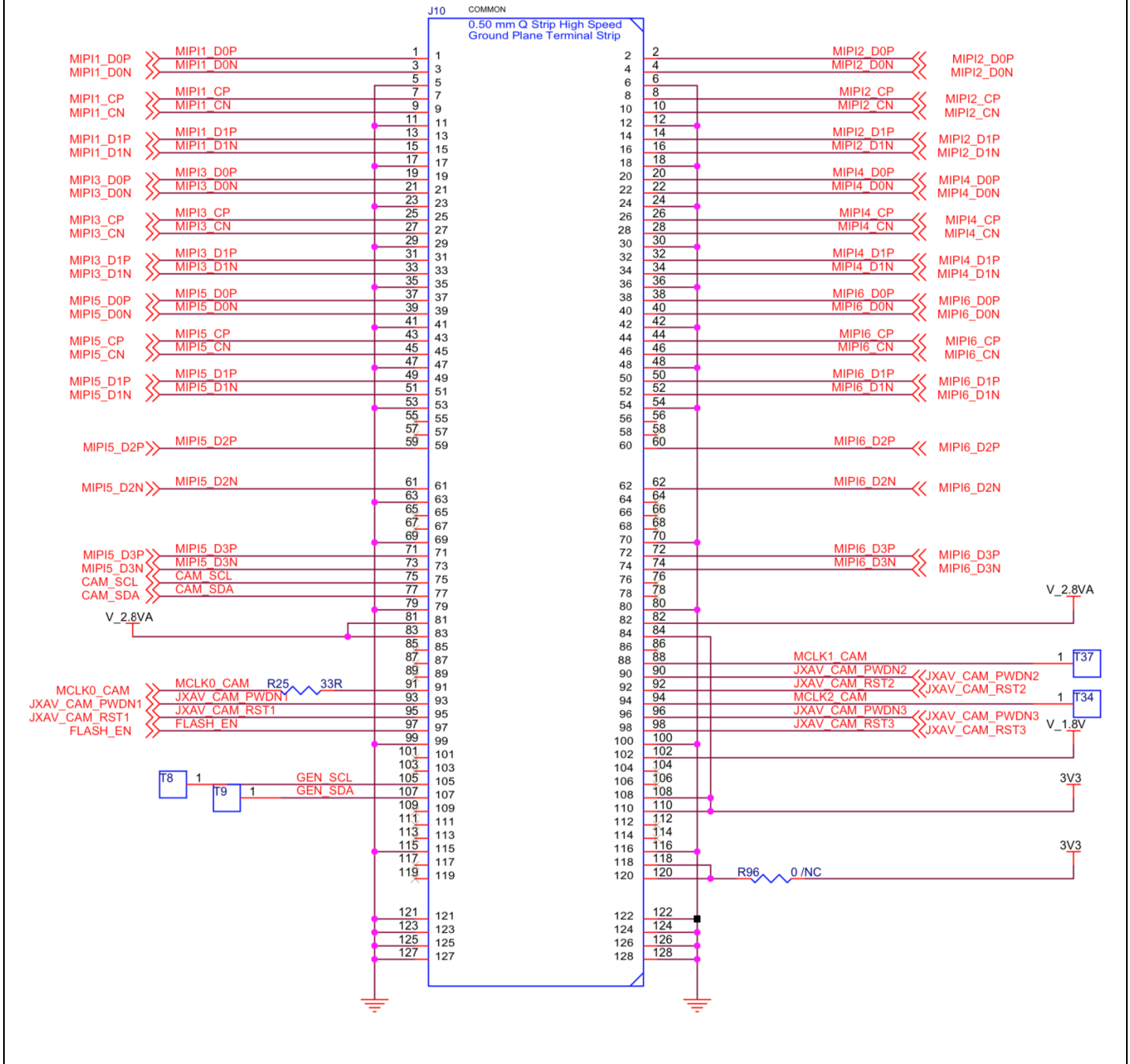

Leopard Imaging Inc.

48820 Kato Rd, Suite 100B, Fremont, CA 94538, USA
 Phone: +1-408-263-0988
 Fax: +1-408-217-1960
 Email: sales@leopardimaging.com
 Website: www.leopardimaging.com

LI-IMX477-MIPI-CS



Camera Spec	
Image sensor	Sony Diagonal 7.857 mm (Type 1/2.3) CMOS Image Sensor IMX477
Optical format	1/2.3"
Number of active pixels	4056 (H) x 3040 (V)
Pixel size	1.55 x 1.55 μm
Color or Mono	Color
Interface	MIPI interface
Lens mount	CS
Weight	~ 58 g
Interfaces	
Interface J1: <ul style="list-style-type: none"> Part#: 20525-030E-02C Number of Positions: 30 Pitch: 0.4 mm Mating I-PEX cable: FAW-1233-03 (300 mm) 	
Interface J4: <ul style="list-style-type: none"> Part#: 1734829-2 Number of Positions: 2 Pitch: 1.25 mm 	
Interface J1: <ul style="list-style-type: none"> Part#: 1734829-2 Number of Positions: 2 Pitch: 1.25 mm 	



Leopard Imaging Inc.

48820 Kato Rd, Suite 100B, Fremont, CA 94538, USA
 Phone: +1-408-263-0988
 Fax: +1-408-217-1960
 Email: sales@leopardimaging.com
 Website: www.leopardimaging.com

Revision History

Revision	Description	Release Date
1.0	First release.	23. Mar. 2019
1.1	Added LI-JXAV-MIPI-ADPT-6CAM-FP board.	06. Nov. 2019
1.2	Deleted info quoted from sensor spec.	26. May. 2022



Leopard Imaging Inc.

48820 Kato Rd, Suite 100B, Fremont, CA 94538, USA
Phone: +1-408-263-0988
Fax: +1-408-217-1960
Email: sales@leopardimaging.com
Website: www.leopardimaging.com