



LEOPARD IMAGING INC

LI-XAVIER-KIT-IMX415CS-X Data Sheet

Key Features

- Compatible with Nvidia® Jetson AGX Xavier™ Developer Kit
- MIPI CSI-2 interface
- Supports up to six cameras
- Two adapter board options
 - LI-JXAV-MIPI-ADPT-4CAM
 - LI-JXAV-MIPI-ADPT-6CAM-FP
- Sony Diagonal 6.43 mm (Type 1/2.8) CMOS Image Sensor IMX415
- Active pixels: 3864 (H) x 2176 (V)
- Color camera
- Length of the I-PEX cable: 300 mm
- Supports multiple length cables
- Connector Part#: 20525-030E-02C
- Allows customization
- Part#:
 - (1 cam) [LI-XAVIER-KIT-IMX415CS](#)
 - (2 cam) [LI-XAVIER-KIT-IMX415CS-D](#)
 - (3 cam) [LI-XAVIER-KIT-IMX415CS-T](#)
 - (4 cam) [LI-XAVIER-KIT-IMX415CS-Q](#)
 - (6 cam) [LI-XAVIER-KIT-IMX415CS-H](#)

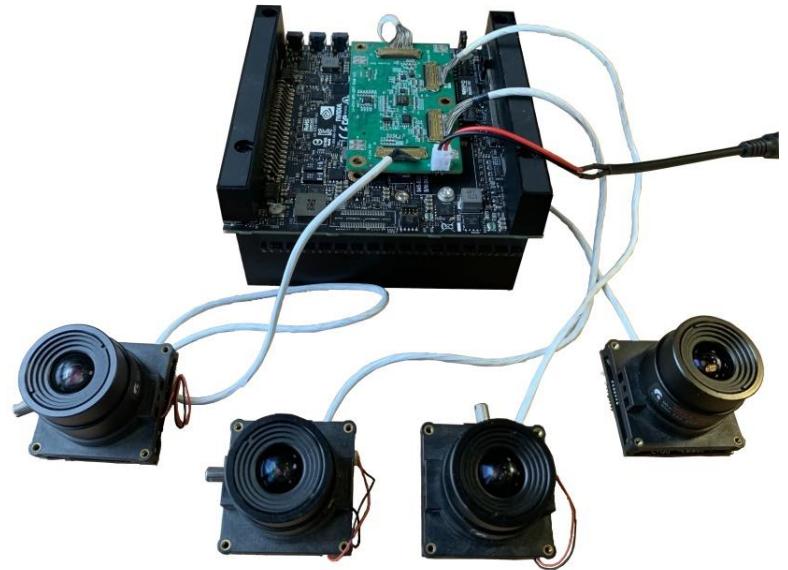

Lens Spec

- Model: ES0522F.IR
- Focal Length: 5.0 mm
- Aperture, F/#: 2.2
- Built in 650 nm IR cut filter
- FOV (D/ H / V): 80.6° / 70.6° / 40.6°
- TV Distortion: < -8%

BOM

Nvidia AGX Xavier Developer Kit not included

#	Items	QTY
1	LI-JXAV-MIPI-ADPT-4CAM or LI-JXAV-MIPI-ADPT-6CAM-FP	1
2	LI-IMX415-MIPI-CS	1, 2, 3, 4 or 6
3	FAW-1233-03 cable	1, 2, 3, 4 or 6

Applications

- Industrial Applications
- Surveillance cameras



Leopard Imaging Inc.

48820 Kato Rd, Suite 100B, Fremont, CA 94538, USA
 Phone: +1-408-263-0988
 Fax: +1-408-217-1960
 Email: sales@leopardimaging.com
 Website: www.leopardimaging.com

LI-XAVIER-KIT-IMX415CS

BOM

#	Items	QTY
1	LI-JXAV-MIPI-ADPT-4CAM	1
2	LI-IMX415-MIPI-CS	1
3	FAW-1233-03 cable	1



LI-XAVIER-KIT-IMX415CS-D

BOM

#	Items	QTY
1	LI-JXAV-MIPI-ADPT-4CAM	1
2	LI-IMX415-MIPI-CS	2
3	FAW-1233-03 cable	2



LI-XAVIER-KIT-IMX415CS-T

BOM

#	Items	QTY
1	LI-JXAV-MIPI-ADPT-4CAM	1
2	LI-IMX415-MIPI-CS	3
3	FAW-1233-03 cable	3

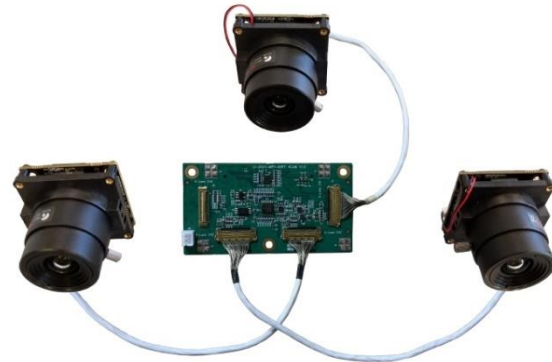

LI-XAVIER-KIT-IMX415CS-Q

BOM

#	Items	QTY
1	LI-JXAV-MIPI-ADPT-4CAM	1
2	LI-IMX415-MIPI-CS	4
3	FAW-1233-03 cable	4

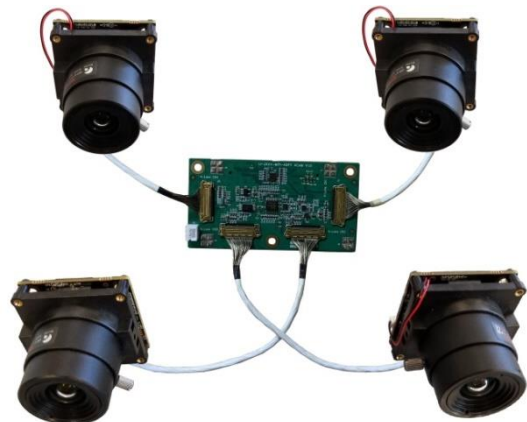

Leopard Imaging Inc.

48820 Kato Rd, Suite 100B, Fremont, CA 94538, USA
Phone: +1-408-263-0988
Fax: +1-408-217-1960
Email: sales@leopardimaging.com
Website: www.leopardimaging.com

LI-XAVIER-KIT-IMX415CS-H

BOM

#	Items	QTY
1	LI-JXAV-MIPI-ADPT-6CAM-FP	1
2	LI-IMX415-MIPI-CS	6
3	FAW-1233-03 cable	6

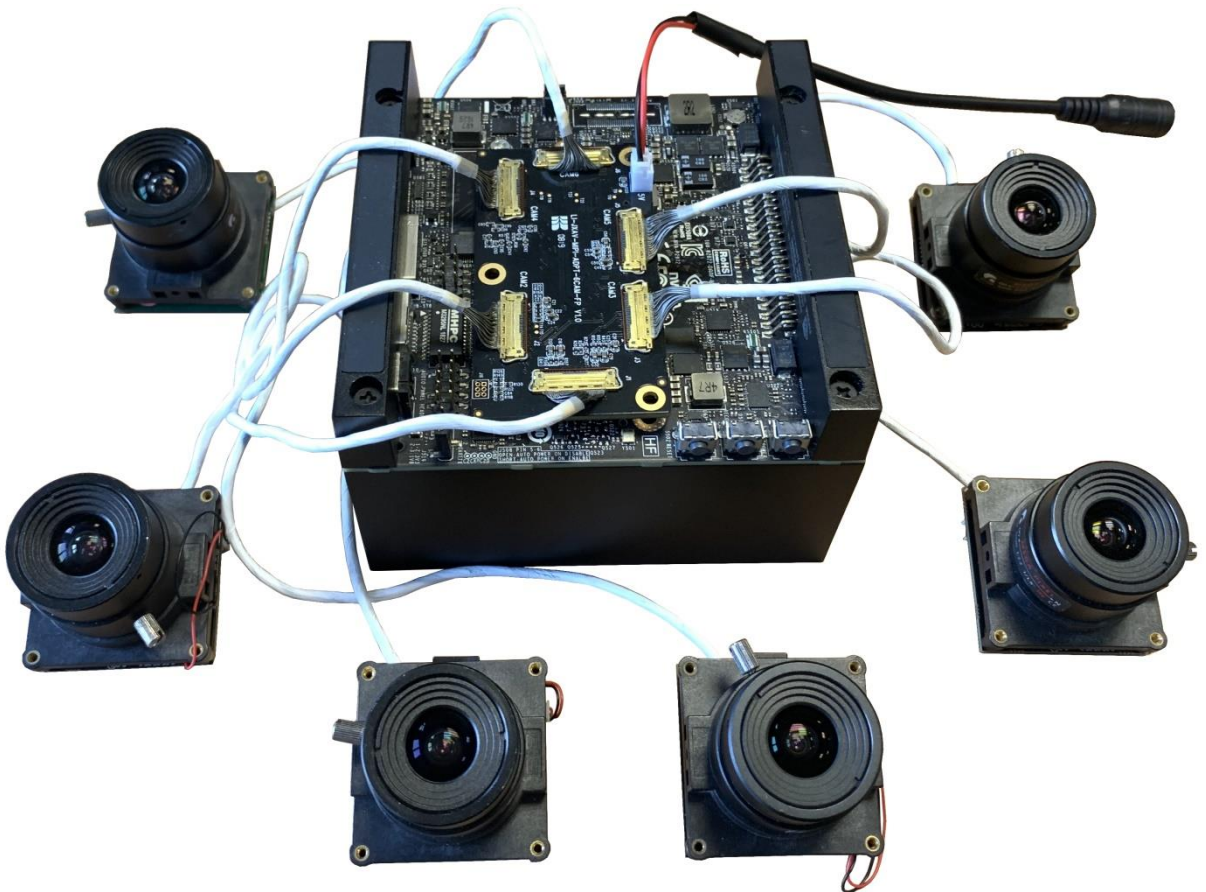
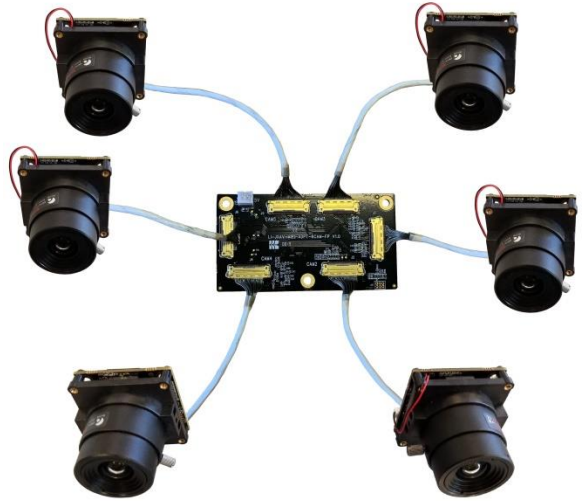

Leopard Imaging Inc.

48820 Kato Rd, Suite 100B, Fremont, CA 94538, USA

Phone: +1-408-263-0988

Fax: +1-408-217-1960

Email: sales@leopardimaging.com

Website: www.leopardimaging.com

Dimensions

LI-IMX415-MIPI-CS

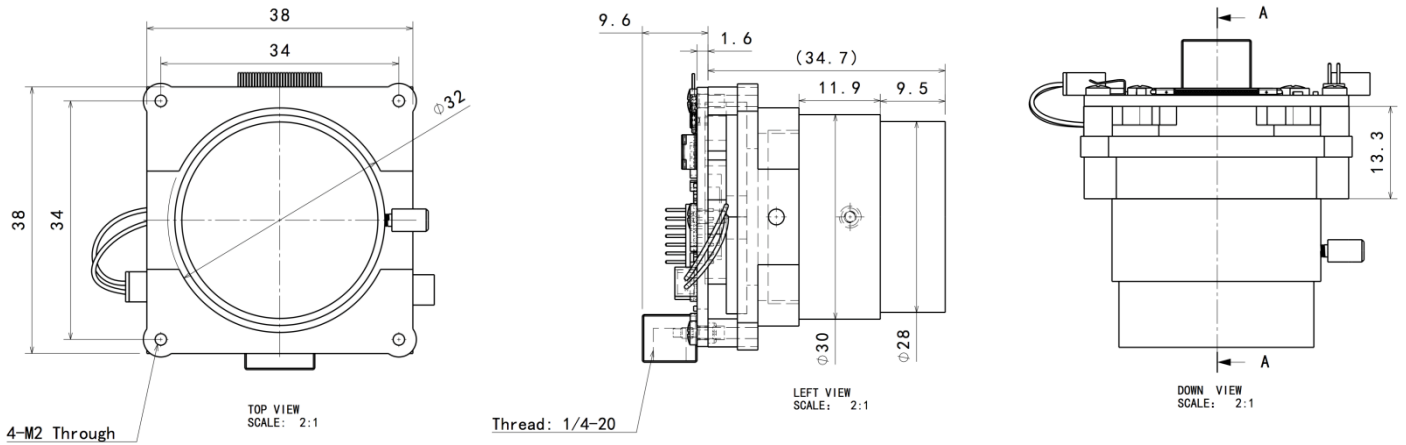

LI-JXAV-MIPI-ADPT-4CAM

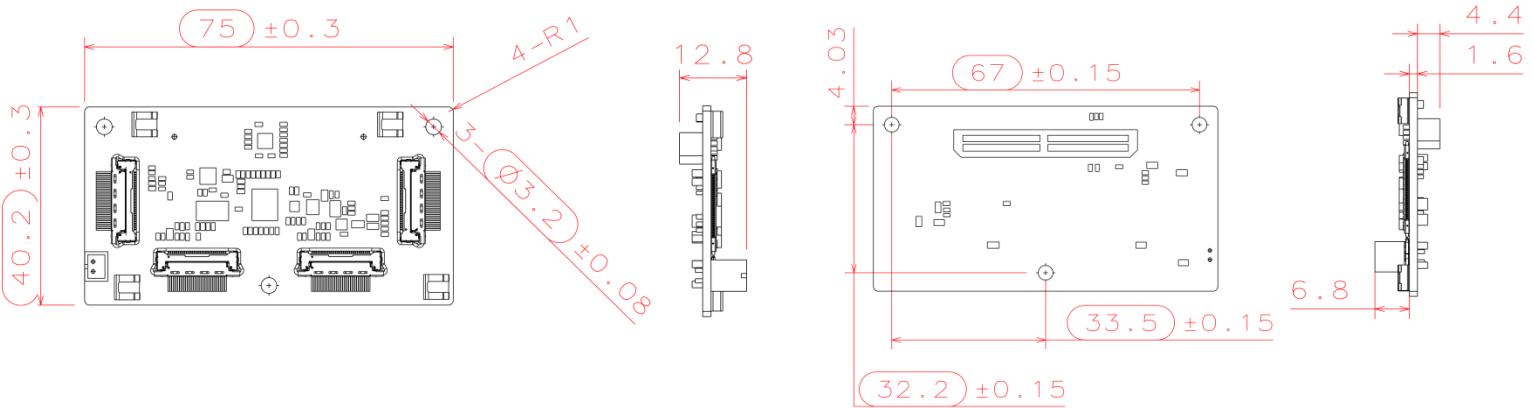

FAW-1233-03

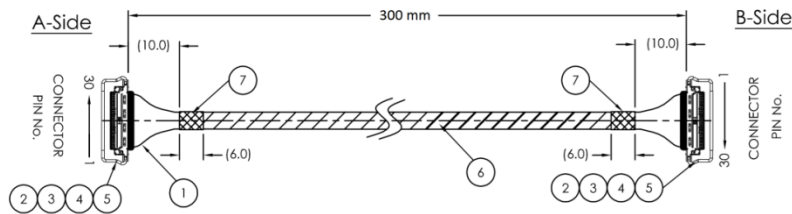

Leopard Imaging Inc.

48820 Kato Rd, Suite 100B, Fremont, CA 94538, USA
 Phone: +1-408-263-0988
 Fax: +1-408-217-1960
 Email: sales@leopardimaging.com
 Website: www.leopardimaging.com

LI-JXAV-MIPI-ADPT-4CAM

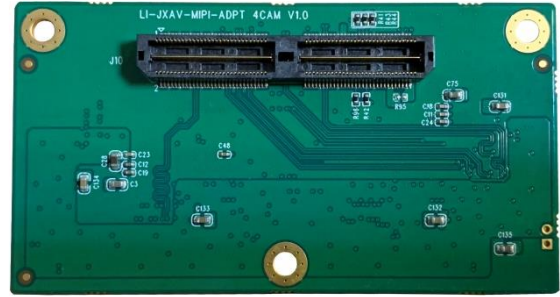

Interfaces

Interface J1

- Part#: 20525-030E-02C
- Number of Positions: 30
- Pitch: 0.4 mm
- Mating I-PEX cable: FAW-1233-03 (300 mm)

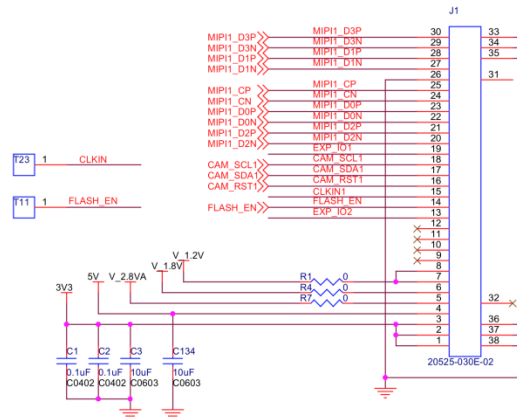

Interface J2

- Part#: 20525-030E-02C
- Number of Positions: 30
- Pitch: 0.4 mm
- Mating I-PEX cable: FAW-1233-03 (300 mm)

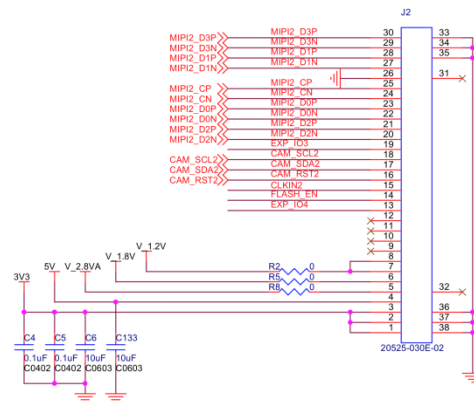

Interface J3

- Part#: 20525-030E-02C
- Number of Positions: 30
- Pitch: 0.4 mm
- Mating I-PEX cable: FAW-1233-03 (300 mm)

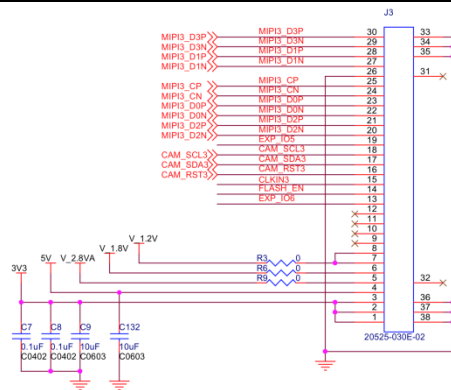

Leopard Imaging Inc.

48820 Kato Rd, Suite 100B, Fremont, CA 94538, USA
 Phone: +1-408-263-0988
 Fax: +1-408-217-1960
 Email: sales@leopardimaging.com
 Website: www.leopardimaging.com

Interface J4

- Part#: 20525-030E-02C
- Number of Positions: 30
- Pitch: 0.4 mm
- Mating I-PEX cable: FAW-1233-03 (300 mm)

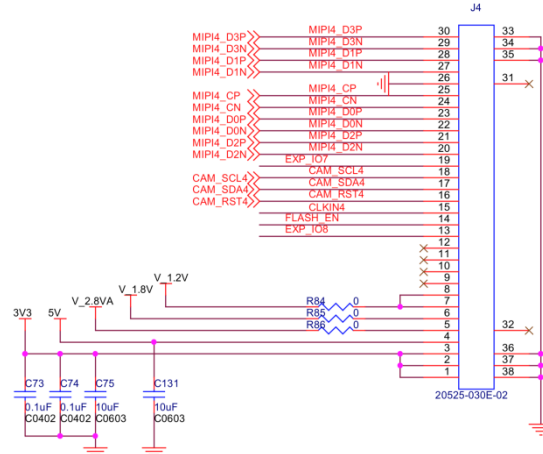

Interface J5

- Part#: 0894000220
- Number of Positions: 2
- Pitch: 2 mm

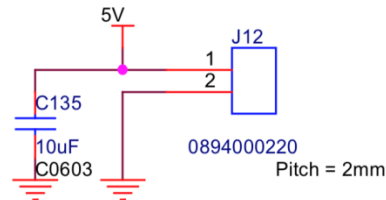

Interface J10

- Part#: QTH-060-01-L-D-A
- Number of Positions: 120
- Number of Rows: 2
- Pitch: 0.5 mm

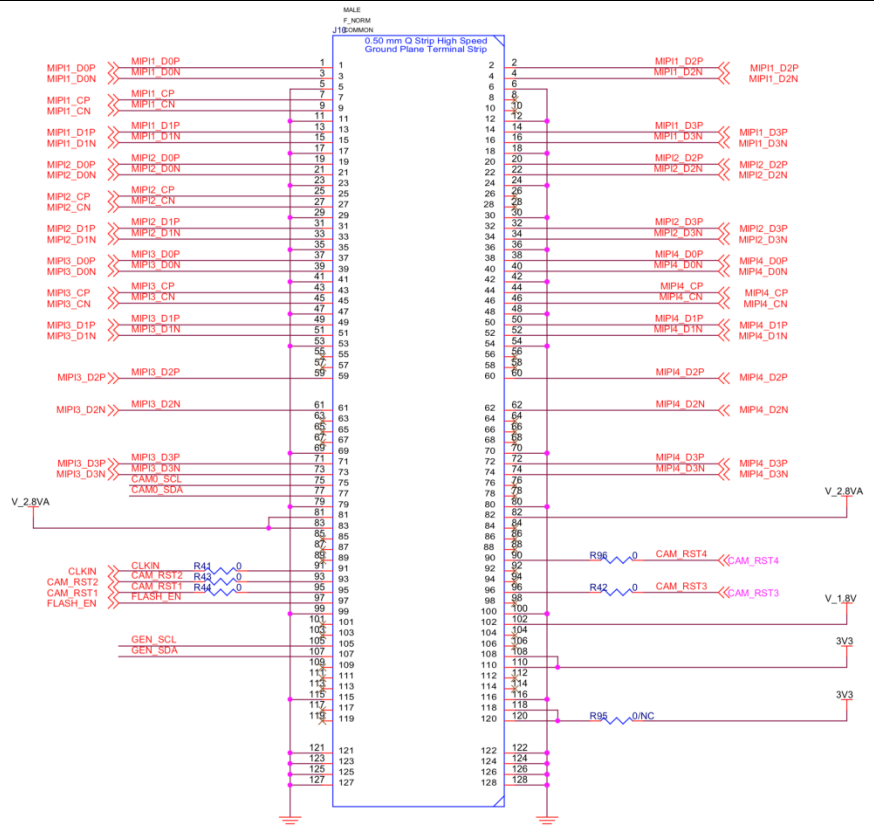

Leopard Imaging Inc.

48820 Kato Rd, Suite 100B, Fremont, CA 94538, USA
 Phone: +1-408-263-0988
 Fax: +1-408-217-1960
 Email: sales@leopardimaging.com
 Website: www.leopardimaging.com

LI-JXAV-MIPI-ADPT-6CAM-FP

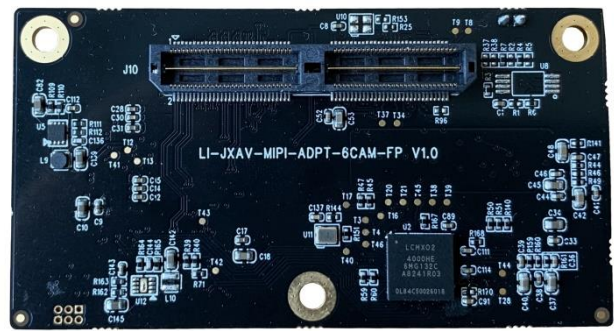
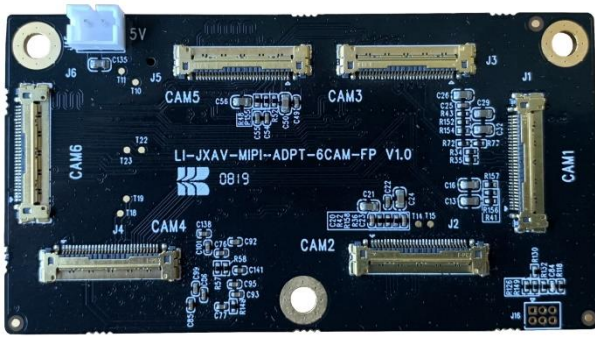

Interfaces

Interface J1 (Camera Channel 1)

- Part#: 20525-030E-02C
- Number of Positions: 30
- Pitch: 0.4 mm
- Mating I-PEX cable: FAW-1233-xx

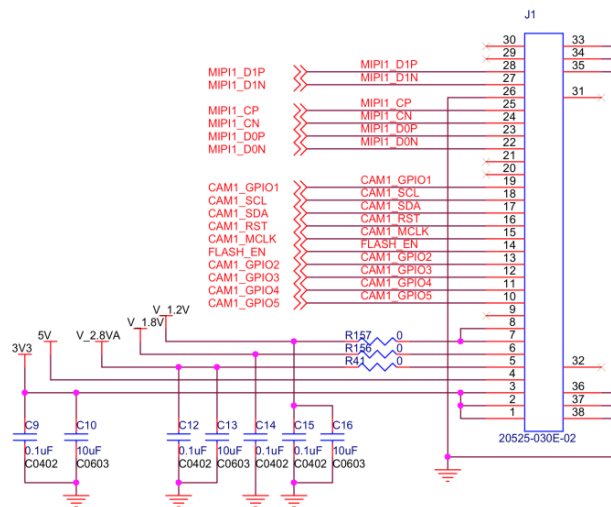

Interface J2 (Camera Channel 2)

- Part#: 20525-030E-02C
- Number of Positions: 30
- Pitch: 0.4 mm
- Mating I-PEX cable: FAW-1233-xx

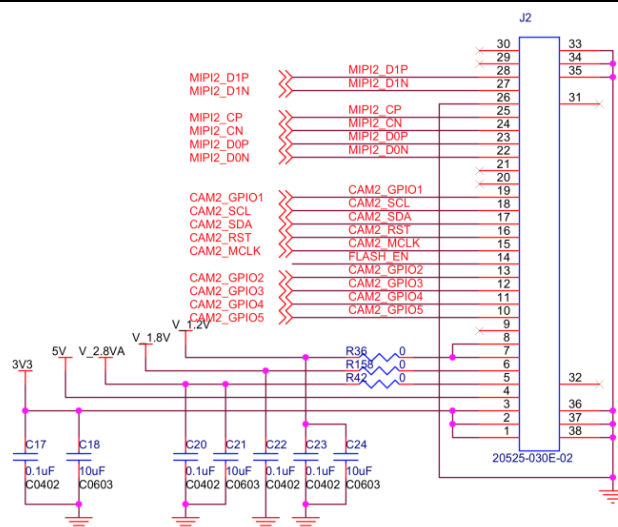

Leopard Imaging Inc.

48820 Kato Rd, Suite 100B, Fremont, CA 94538, USA
 Phone: +1-408-263-0988
 Fax: +1-408-217-1960
 Email: sales@leopardimaging.com
 Website: www.leopardimaging.com

Interface J3 (Camera Channel 3)

- Part#: 20525-030E-02C
- Number of Positions: 30
- Pitch: 0.4 mm
- Mating I-PEX cable: FAW-1233-xx

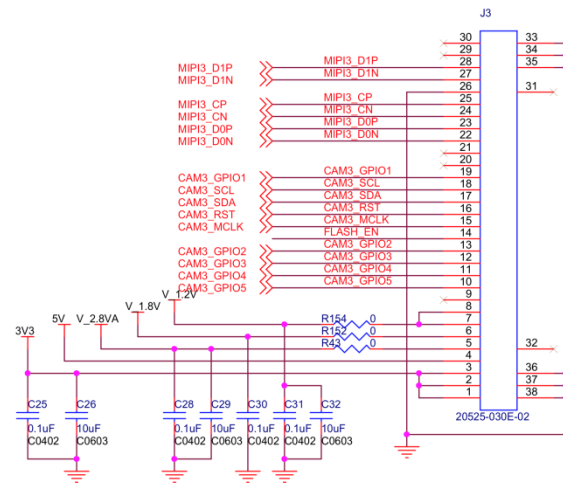

Interface J4 (Camera Channel 4)

- Part#: 20525-030E-02C
- Number of Positions: 30
- Pitch: 0.4 mm
- Mating I-PEX cable: FAW-1233-xx

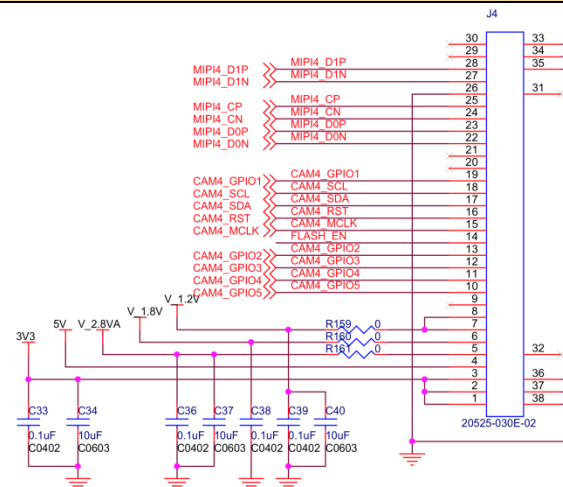

Interface J5 (Camera Channel 5)

- Part#: 20525-030E-02C
- Number of Positions: 30
- Pitch: 0.4 mm
- Mating I-PEX cable: FAW-1233-xx

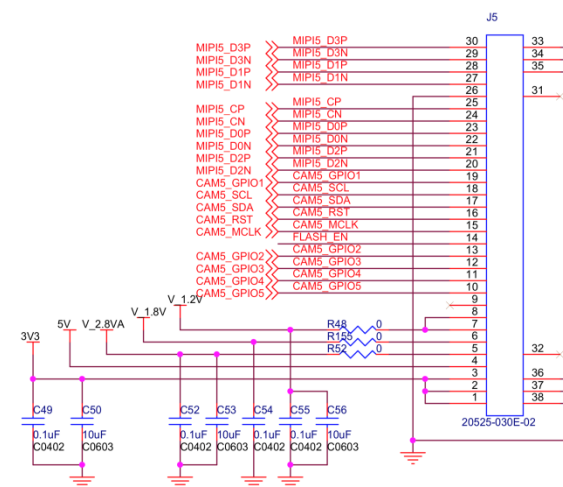

Leopard Imaging Inc.

48820 Kato Rd, Suite 100B, Fremont, CA 94538, USA
 Phone: +1-408-263-0988
 Fax: +1-408-217-1960
 Email: sales@leopardimaging.com
 Website: www.leopardimaging.com

Interface J6 (Camera Channel 6)

- Part#: 20525-030E-02C
- Number of Positions: 30
- Pitch: 0.4 mm
- Mating I-PEX cable:
FAW-1233-xx

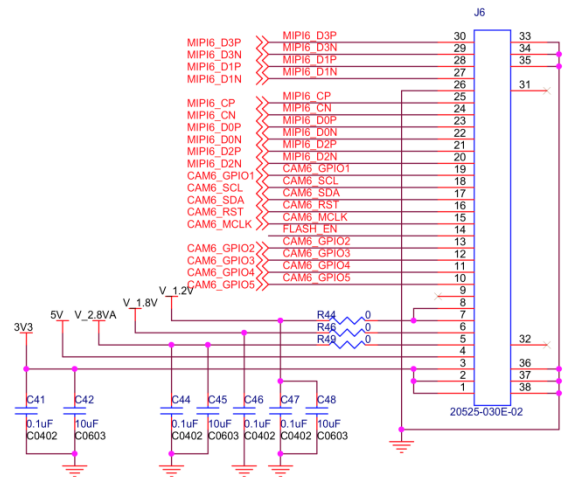

Interface J16 (FPGA Programming Interface)

- Part#: 20021311-00006T4LF
- Number of Positions: 6
- Pitch: 0.050" (1.27 mm)
- Number of Rows: 2

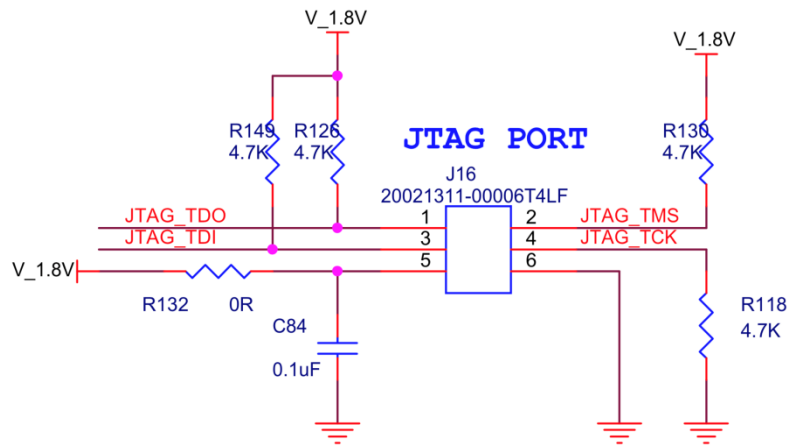

Interface J15 (External Power Input Interface)

- Part#: 0894000220
- Number of Positions: 2
- Pitch: 2 mm

External Input Power

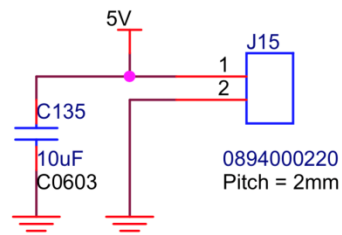

Leopard Imaging Inc.

48820 Kato Rd, Suite 100B, Fremont, CA 94538, USA
 Phone: +1-408-263-0988
 Fax: +1-408-217-1960
 Email: sales@leopardimaging.com
 Website: www.leopardimaging.com

Interface J10 (To Xavier)

- Part#: QTH-060-01-L-D-A
- Number of Positions: 120
- Number of Rows: 2
- Pitch: 0.5 mm

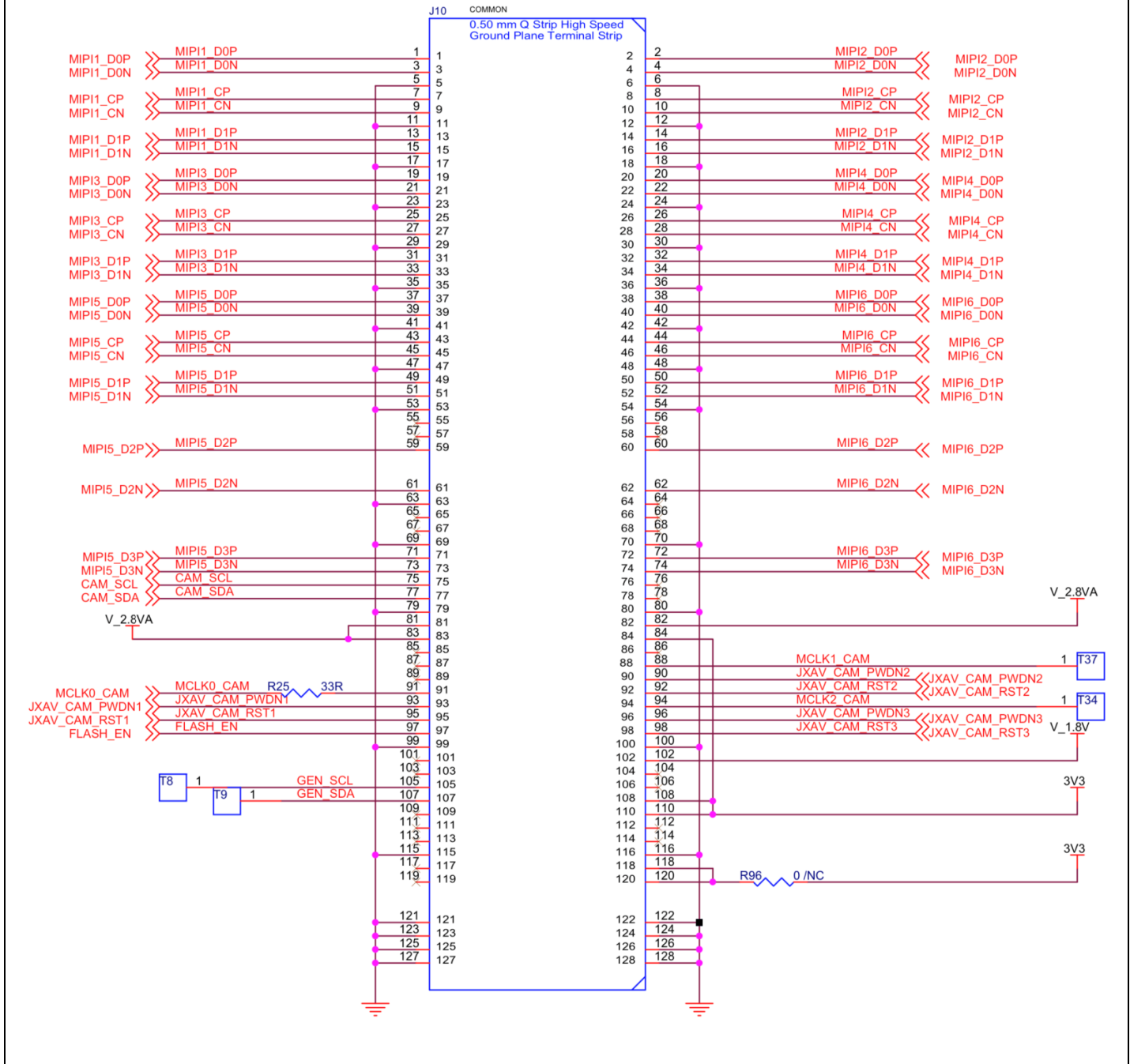

Leopard Imaging Inc.

48820 Kato Rd, Suite 100B, Fremont, CA 94538, USA
 Phone: +1-408-263-0988
 Fax: +1-408-217-1960
 Email: sales@leopardimaging.com
 Website: www.leopardimaging.com

LI-IMX415-MIPI-CS



Camera Spec	
Image sensor	Sony Diagonal 6.43 mm (Type 1/2.8) CMOS Image Sensor IMX415
Optical format	1/2.8"
Number of active pixels	3864 (H) x 2176 (V)
Pixel size	1.45 x 1.45 μm
Color or Mono	Color
Interface	MIPI interface
Lens mount	CS
Weight	~ 58 g
Interfaces	
Interface J4: <ul style="list-style-type: none"> Part#: 20525-030E-02C Number of Positions: 30 Pitch: 0.4 mm Mating I-PEX cable: FAW-1233-03 (300 mm) 	
Interface J3: <ul style="list-style-type: none"> Part#: 1734829-2 Number of Positions: 2 Pitch: 1.25 mm 	
Interface J6: <ul style="list-style-type: none"> Part#: 1734829-2 Number of Positions: 2 Pitch: 1.25 mm 	



Leopard Imaging Inc.

48820 Kato Rd, Suite 100B, Fremont, CA 94538, USA
 Phone: +1-408-263-0988
 Fax: +1-408-217-1960
 Email: sales@leopardimaging.com
 Website: www.leopardimaging.com

Revision History

Revision	Description	Release Date
1.0	First release.	02. Feb. 2020
1.1	Deleted info quoted from sensor spec.	26. May. 2022



Leopard Imaging Inc.

48820 Kato Rd, Suite 100B, Fremont, CA 94538, USA
Phone: +1-408-263-0988
Fax: +1-408-217-1960
Email: sales@leopardimaging.com
Website: www.leopardimaging.com