



LEOPARD IMAGING INC

Rev 1.3

LI-JETSON-KIT-IMX264M12-X Data Sheet

Key Features

- Compatible with Nvidia Jetson TX1/TX2 Developer Kit
- MIPI CSI-2 interface
- Supports up to six cameras
- Two adapter board options
 - LI-JTX1-MIPI-ADPT
Includes three 4-lane interfaces
 - LI-JTX1-MIPI-ADPT-6CAM
Includes six 2-lane interfaces
- Sony Diagonal 11.1 mm (Type 2/3) CMOS Image Sensor IMX264
- Active pixels: 2464 (H) x 2056 (V)
- Pixel size: 3.45 x 3.45 μm
- Color camera
- Global shutter
- Length of the I-PEX cable: 300 mm
- Supports multiple length cables
- Connector Part#: 20525-030E-02C
- Supports M12 x P0.5 lens
- Allows customization
- Part#:

- (1 cam) [LI-JETSON-KIT-IMX264M12](#)
- (2 cam) [LI-JETSON-KIT-IMX264M12-D](#)
- (3 cam) [LI-JETSON-KIT-IMX264M12-T](#)
- (6 cam) [LI-JETSON-KIT-IMX264M12-H](#)

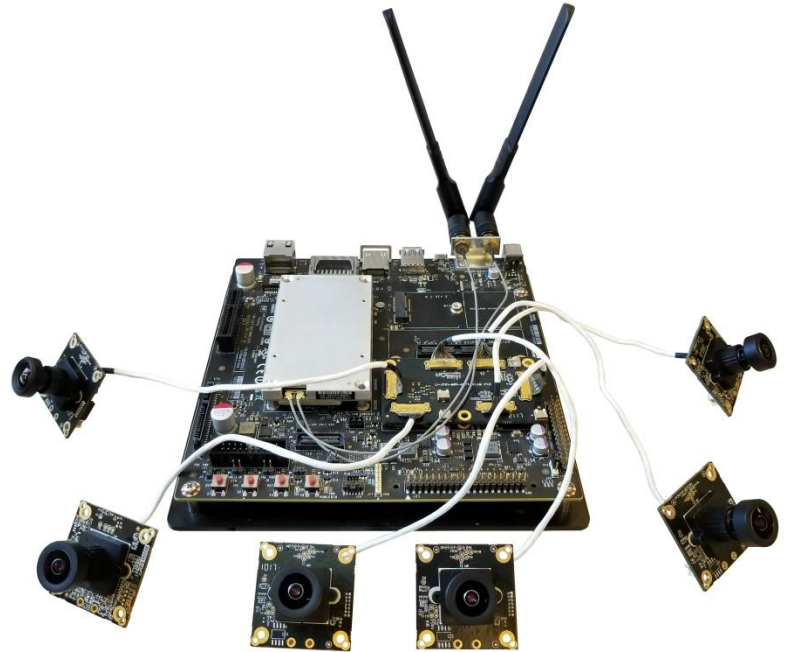

Lens Spec

- Model: FIFO-F1225FM
- Focal Length: 12 mm
- Aperture, F/#: 2.5
- Built in 650 nm IR cut filter
- FOV (H): 37°
- TV Distortion: < -1.2 %

BOM

Nvidia TX1/TX2 Developer Kit not included

#	Items	QTY
1	LI-JTX1-MIPI-ADPT or LI-JTX1-MIPI-ADPT-6CAM	1
2	LI-IMX264-MIPI-M12	1,2,3 or 6
3	FAW-1233-03 cable	1,2,3 or 6



Leopard Imaging Inc.

48820 Kato Road, Suite 100B, Fremont, CA 94538, USA
 Phone: +1-408-263-0988
 Fax: +1-408-217-1960
 Email: sales@leopardimaging.com
 Website: www.leopardimaging.com

LI-JETSON-KIT-IMX264M12

BOM

#	Items	QTY
1	LI-JTX1-MIPI-ADPT	1
2	LI-IMX264-MIPI-M12	1
3	FAW-1233-03 cable	1



LI-JETSON-KIT-IMX264M12-D

BOM

#	Items	QTY
1	LI-JTX1-MIPI-ADPT	1
2	LI-IMX264-MIPI-M12	2
3	FAW-1233-03 cable	2



LI-JETSON-KIT-IMX264M12-T

BOM

#	Items	QTY
1	LI-JTX1-MIPI-ADPT	1
2	LI-IMX264-MIPI-M12	3
3	FAW-1233-03 cable	3



LI-JETSON-KIT-IMX264M12-H

BOM

#	Items	QTY
1	LI-JTX1-MIPI-ADPT-6CAM	1
2	LI-IMX264-MIPI-M12	6
3	FAW-1233-03 cable	6

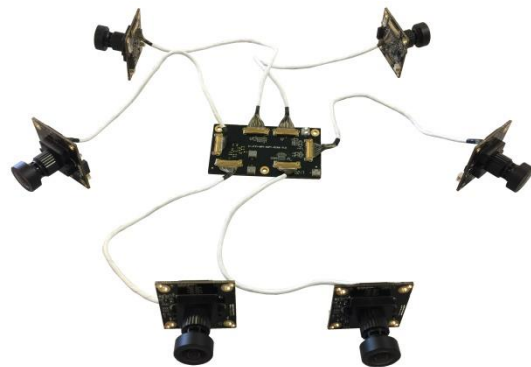

Leopard Imaging Inc.

48820 Kato Road, Suite 100B, Fremont, CA 94538, USA

Phone: +1-408-263-0988

Fax: +1-408-217-1960

Email: sales@leopardimaging.com

Website: www.leopardimaging.com

Dimensions

LI-IMX264-MIPI-M12

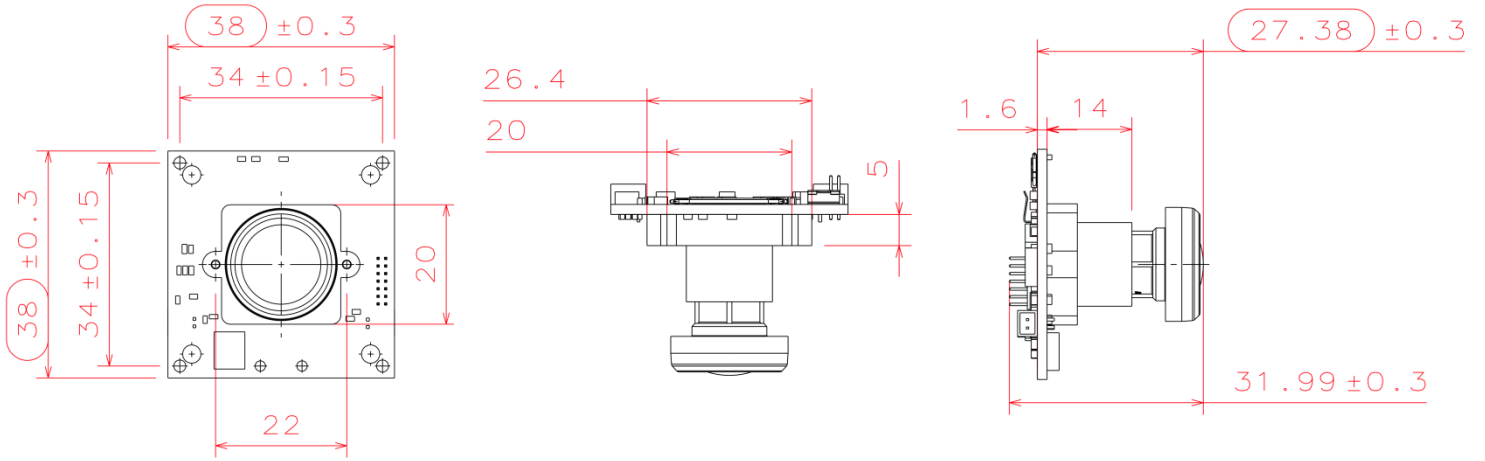

LI-JTX1-MIPI-ADPT

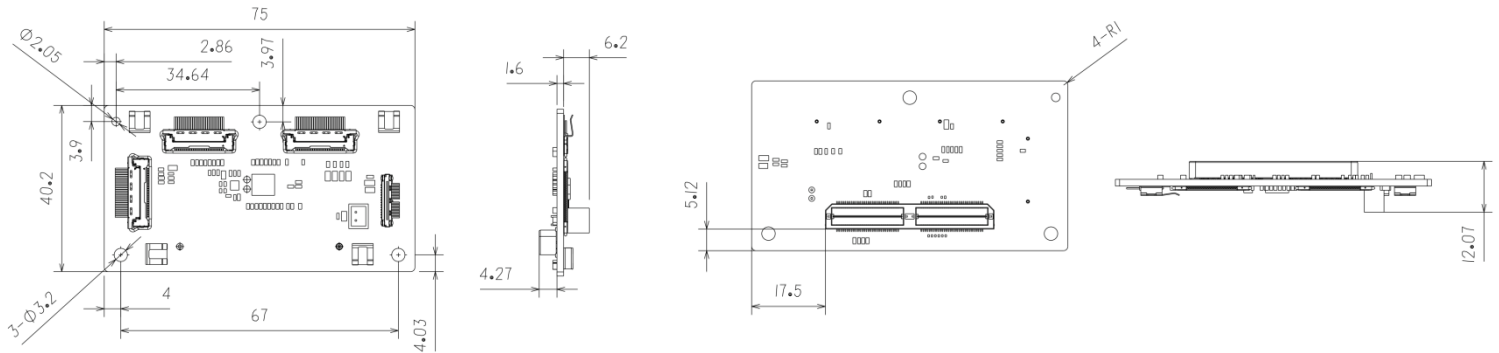

LI-JTX1-MIPI-ADPT-6CAM

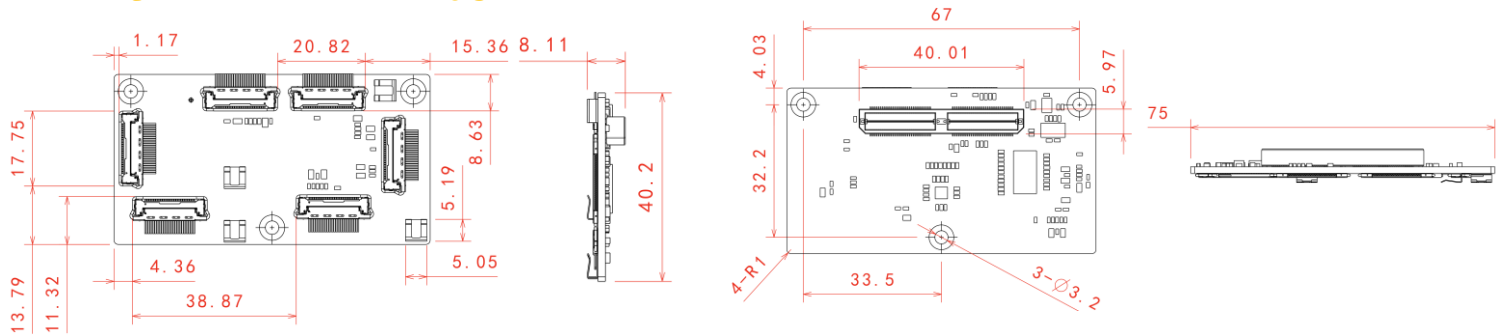

FAW-1233-03

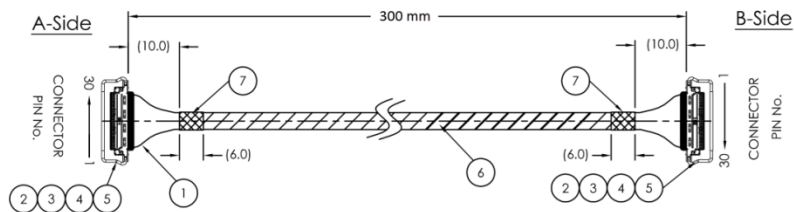

Leopard Imaging Inc.

48820 Kato Road, Suite 100B, Fremont, CA 94538, USA
 Phone: +1-408-263-0988
 Fax: +1-408-217-1960
 Email: sales@leopardimaging.com
 Website: www.leopardimaging.com

LI-JTX1-MIPI-ADPT

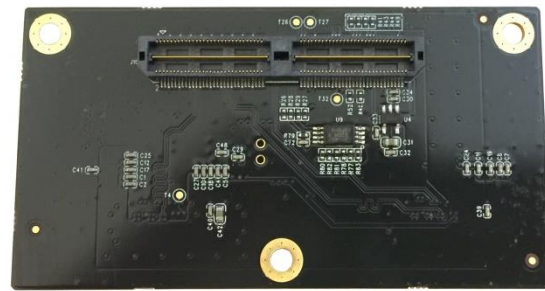
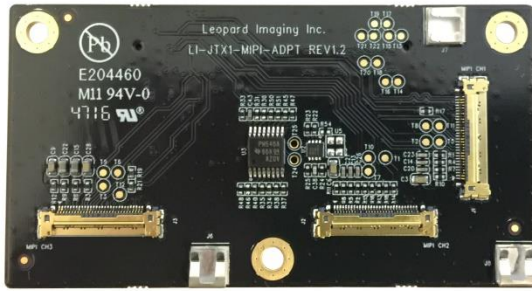

Interfaces

Interface J1

- Part#: 20525-030E-02C
- Number of Positions: 30
- Pitch: 0.4 mm
- Mating I-PEX cable: FAW-1233-03 (300 mm)

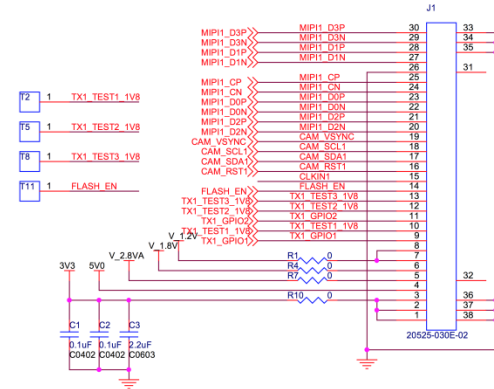

Interface J2

- Part#: 20525-030E-02C
- Number of Positions: 30
- Pitch: 0.4 mm
- Mating I-PEX cable: FAW-1233-03 (300 mm)

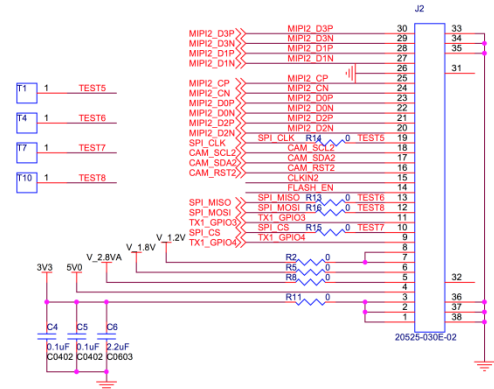

Interface J3

- Part#: 20525-030E-02C
- Number of Positions: 30
- Pitch: 0.4 mm
- Mating I-PEX cable: FAW-1233-03 (300 mm)

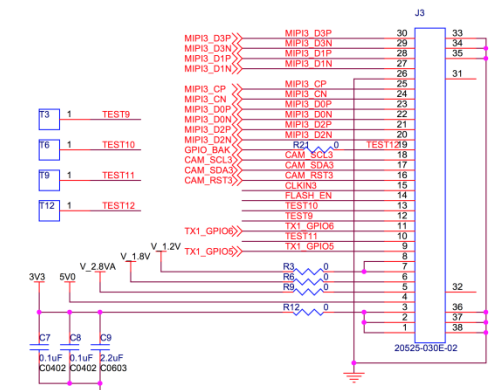

Leopard Imaging Inc.

48820 Kato Road, Suite 100B, Fremont, CA 94538, USA
 Phone: +1-408-263-0988
 Fax: +1-408-217-1960
 Email: sales@leopardimaging.com
 Website: www.leopardimaging.com

Interface J10

- Part#: QTH-060-01-L-D-A
- Number of Positions: 120
- Number of Rows: 2
- Pitch: 0.5 mm

Vertical Mating connector of Jetson TX1 J22 QTH-060-01-D-A

MIPI Channel 1

MIPI Channel 2

MIPI Channel 3

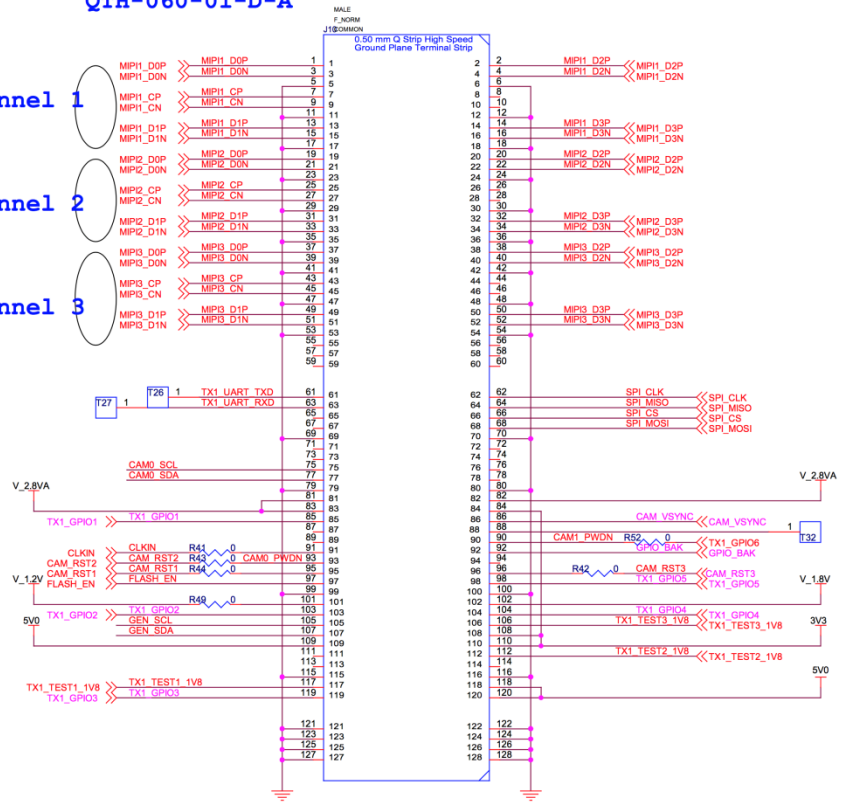

Leopard Imaging Inc.

48820 Kato Road, Suite 100B, Fremont, CA 94538, USA
 Phone: +1-408-263-0988
 Fax: +1-408-217-1960
 Email: sales@leopardimaging.com
 Website: www.leopardimaging.com

LI-JTX1-MIPI-ADPT-6CAM

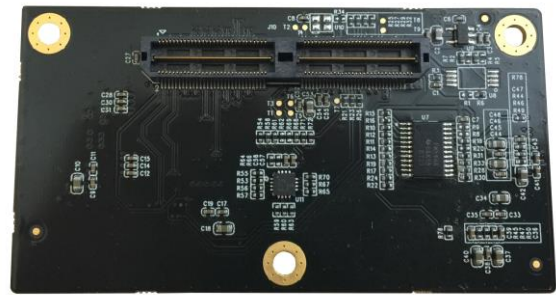
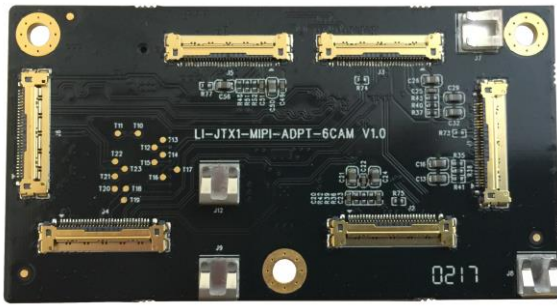

Interfaces

Interface J1

- Part#: 20525-030E-02C
- Number of Positions: 30
- Pitch: 0.4 mm
- Mating I-PEX cable: FAW-1233-03 (300 mm)

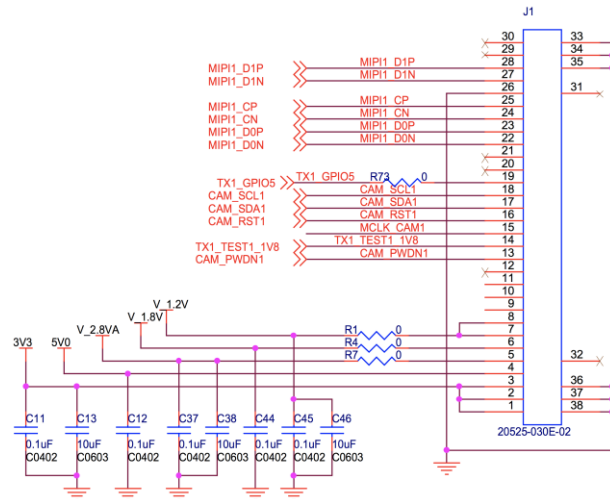

Interface J2

- Part#: 20525-030E-02C
- Number of Positions: 30
- Pitch: 0.4 mm
- Mating I-PEX cable: FAW-1233-03 (300 mm)

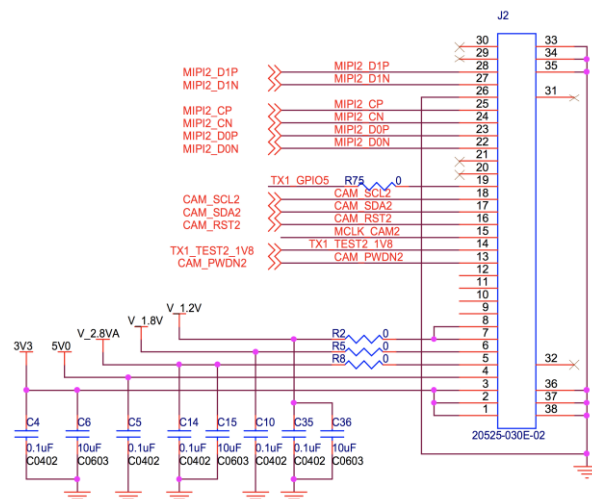

Leopard Imaging Inc.

48820 Kato Road, Suite 100B, Fremont, CA 94538, USA
Phone: +1-408-263-0988
Fax: +1-408-217-1960
Email: sales@leopardimaging.com
Website: www.leopardimaging.com

Interface J3

- Part#: 20525-030E-02C
- Number of Positions: 30
- Pitch: 0.4 mm
- Mating I-PEX cable: FAW-1233-03 (300 mm)

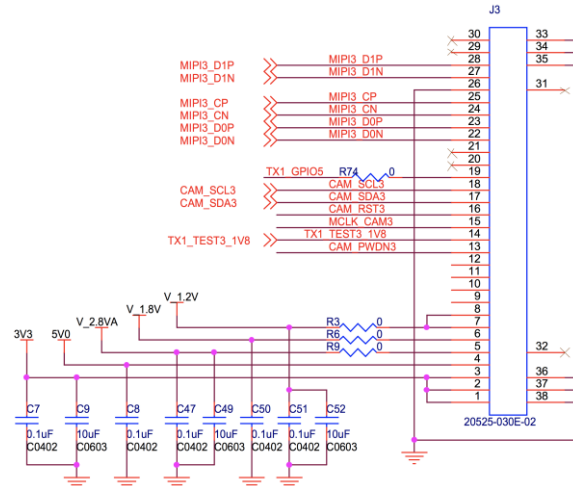

Interface J4

- Part#: 20525-030E-02C
- Number of Positions: 30
- Pitch: 0.4 mm
- Mating I-PEX cable: FAW-1233-03 (300 mm)

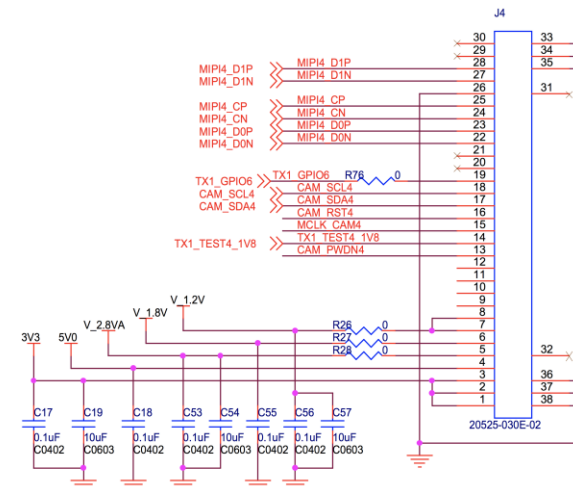

Interface J5

- Part#: 20525-030E-02C
- Number of Positions: 30
- Pitch: 0.4 mm
- Mating I-PEX cable: FAW-1233-03 (300 mm)

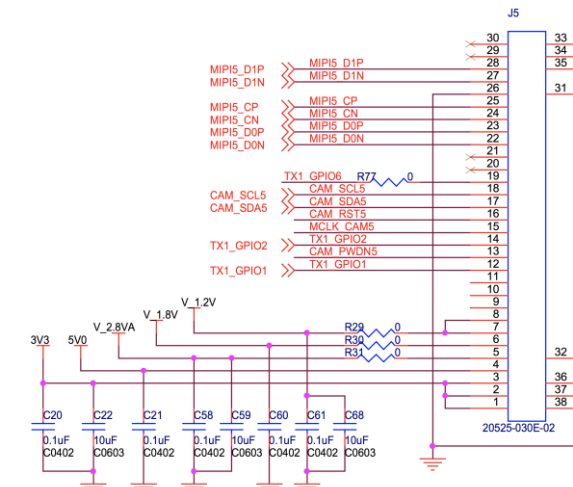

Leopard Imaging Inc.

48820 Kato Road, Suite 100B, Fremont, CA 94538, USA
 Phone: +1-408-263-0988
 Fax: +1-408-217-1960
 Email: sales@leopardimaging.com
 Website: www.leopardimaging.com

Interface J9

- Part#: 20525-030E-02C
- Number of Positions: 30
- Pitch: 0.4 mm
- Mating I-PEX cable: FAW-1233-03 (300 mm)

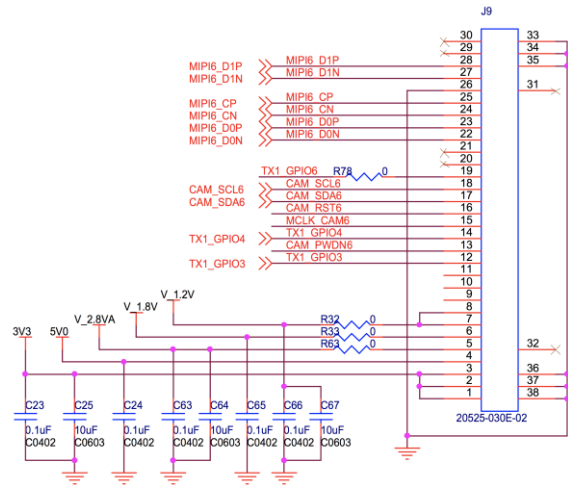

Interface J10

- Part#: QTH-060-01-L-D-A
- Number of Positions: 120
- Number of Rows: 2
- Pitch: 0.5 mm

Vertical Mating connector of Jetson TX1 J22 QTH-060-01-D-A

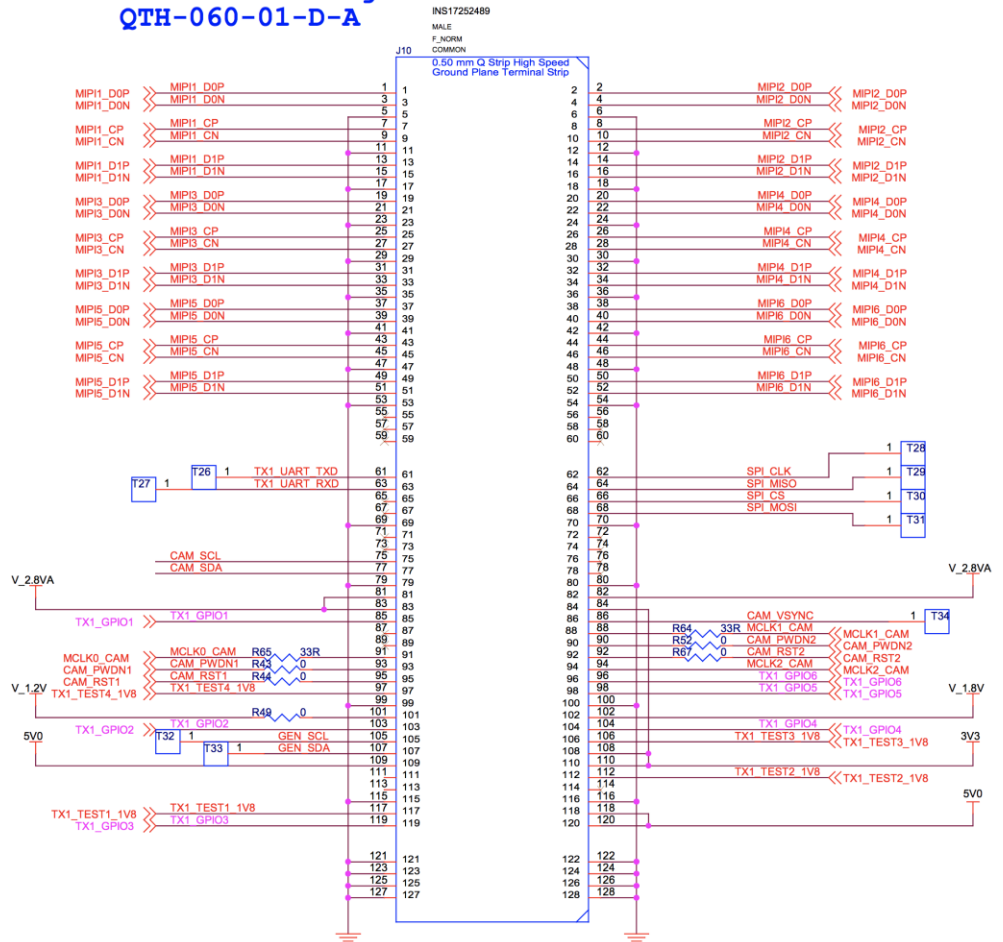

Leopard Imaging Inc.

48820 Kato Road, Suite 100B, Fremont, CA 94538, USA
 Phone: +1-408-263-0988
 Fax: +1-408-217-1960
 Email: sales@leopardimaging.com
 Website: www.leopardimaging.com

LI-IMX264-MIPI-M12



Camera Spec	
Image sensor	Sony Diagonal 11.1 mm (Type 2/3) CMOS Image Sensor IMX264
Optical format	2/3"
Number of active pixels	2464 (H) x 2056(V)
Pixel size	3.45 x 3.45 μm
Color or Mono	Color
Interface	MIPI interface
Lens mount	M12
Weight	~ 14 g
Interfaces	
Interface J4:	<ul style="list-style-type: none"> Part#: 20525-030E-02C Number of Positions: 30 Pitch: 0.4 mm Mating I-PEX cable: FAW-1233-03 (300 mm)
Interface J8:	<ul style="list-style-type: none"> Part#: 1734829-2 Number of Positions: 2 Pitch: 1.25 mm
Interface J2:	<ul style="list-style-type: none"> Part#: 20021321-00010C4LF Number of Positions: 10 Pitch: 1.27 mm



Leopard Imaging Inc.

48820 Kato Road, Suite 100B, Fremont, CA 94538, USA
 Phone: +1-408-263-0988
 Fax: +1-408-217-1960
 Email: sales@leopardimaging.com
 Website: www.leopardimaging.com