



LEOPARD
IMAGING

LI-AR0234CS-ST100-GM2C-120H



Address:

910 Auburn Ct
Fremont, CA 94538
USA



Phone:

+1 (408)263-0988

Fax:

+1 (408)217-1960



Sales:

sales@leopardimaging.com

Support:

support@leopardimaging.com

INTRODUCTION

The LI-AR0234CS-ST100-GM2C-120H is the professional 3D depth camera where cutting-edge technology meets effortless usability. Equipped with ON Semiconductor 2.3MP CMOS digital image sensor AR0234CS, our camera provides unparalleled depth sensing capabilities, allowing ease while teams or enthusiasts work at the edge of ADAS, autonomous driving, robotics and immersive enjoyments. Dive into a world of limitless possibilities with this camera, where every detail is captured with precision and every interaction is taken to new heights.

FEATURES & HIGHLIGHTS

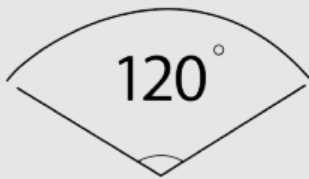

With 121.5° horizontal and 147.5° diagonal field of view, it helps to perceive the world in 3D with greater depth and dimension of field, sharper image quality and more details.



2 x Global shutters capture the entire frame at the same time, freeze the motion at a specific point in time, offering an accurate representation of moving subjects without distortion.



It is easy to deploy the camera in different systems and environments thanks to its flat bottom and flexible mounting options.

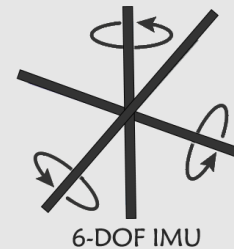

Built-in 6-axis IMU for enhanced spatial and positional awareness.

APPLICATIONS

- Bar Code Scanner
- 3D Scanning
- Positional Tracking
- Iris Scanning
- Machine Vision
- Augmented Reality
- Virtual Reality
- Biometrics
- Gesture Recognition
- Depth Sensing

TECHNICAL SPECIFICATIONS

General	
Use environment	Indoor / Outdoor
Baseline	100 mm
IP Rating	IP67
Video Output	1200P @ 60 fps with output resolution side-by-side 2 × (1920 × 1200) 1200P @ 30 fps with output resolution side-by-side 2 × (1920 × 1200)
Power Supply Range	9 ~ 19 VDC
Power Consumption (NVIDIA® AGX Xavier™)	118 mA @ 12 VDC (2 * 1920 × 1200 @ 60 fps)
IMU (Inertial Measurement Unit)	BMI088
Serializer	Maxim GMSL2
Part#	LI-AR0234CS-ST100-GM2C-120H
Depth	
Depth Frame Rate	TBD
Depth Range	TBD
Depth Technology	Neural Stereo Depth Sensing
Object Detection	
Object Types	Vehicles, persons, custom objects
Object Tracking	Supported
Detection Outputs	Location, unique ID, bounding boxes 2D, segmentation masks
Image Sensor	
Sensor	ON Semiconductor 2.3MP CMOS Image Sensor AR0234CS (QTY: 2)
Optical Format	1/2.6"
Resolution	1920 (H) × 1200 (V) (active pixels)
Pixel Size	3.0 × 3.0 μm
Output Format	10-bit RAW
Color / Mono	Color
Shutter	Global shutter

LENS SPECIFICATIONS

Focal Length	2.8 mm
Aperture, F/#	2.0
Field of View (FOV)	147.5° (diagonal) / 121.5° (horizontal) / 73.5° vertical
Optical Distortion	< -65.3%
Relative Illumination	> 30%
Glass Cover	No
IR Filter	650 nm IR cut filter
Lens Mount	Active Alignment (AA)

PHYSICAL, ENVIRONMENTAL, & CERTIFICATION

Physical Features	
Weight	~ 156 g
Size	131.0 (L) × 25.0 (W) × 44.33 (D) mm
Connector	Fakra Z type connector
Mounting Mechanism	<ul style="list-style-type: none"> • One 1/4"-20 UNC-2B thread mounting point. Thread depth: 6 mm • Four M3 × P0.5-6H thread mounting points. Thread depth: 4 mm • Tripod 
Environmental Features	
Operating Temp	-20°C ~ +50°C
Storage Temp	-40°C ~ +70°C

DIMENSIONS

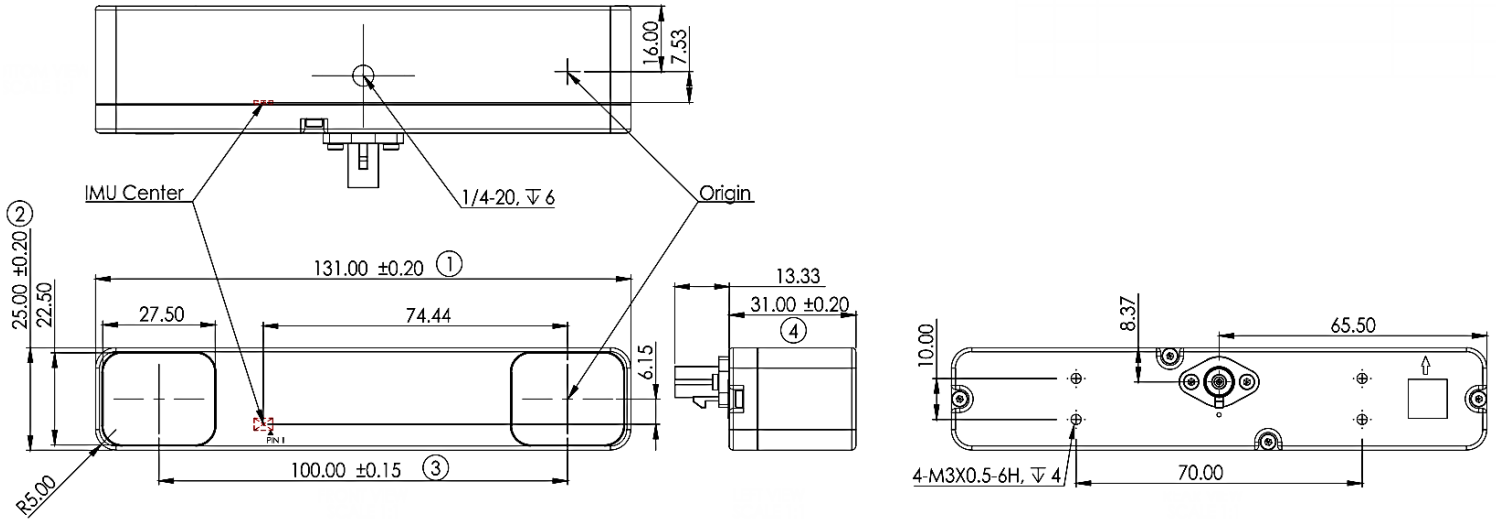

NOTE:

- Other unmarked tolerances refer to the tolerance table.
- ⊗ marked are important sizes.
- All materials are compliant with RoHS requirements.
- IMU location is shown in the drawing.
- Unit: mm

TOLERANCE TABLE

LENGTH TOLERANCE		CHAMFER TOLERANCE		ANGLE TOLERANCE	
Size X	Tolerance	Size X	Tolerance	Size X	Tolerance
0.5 < X ≤ 3	±0.1	0.5 < X ≤ 3	±0.2	X ≤ 10	±1°
3 < X ≤ 6	±0.1	3 < X ≤ 6	±0.5	10 < X ≤ 50	±30'
6 < X ≤ 30	±0.2	6 < X ≤ 30	±1	50 < X ≤ 120	±20'
30 < X ≤ 120	±0.3	X > 30	±2	120 < X ≤ 400	±10'
120 < X ≤ 400	±0.5			X > 400	±5'
400 < X ≤ 1000	±0.8				
X > 1000	±1.2				

IMAGE ORIENTATION



SYSTEM BLOCK DIAGRAM

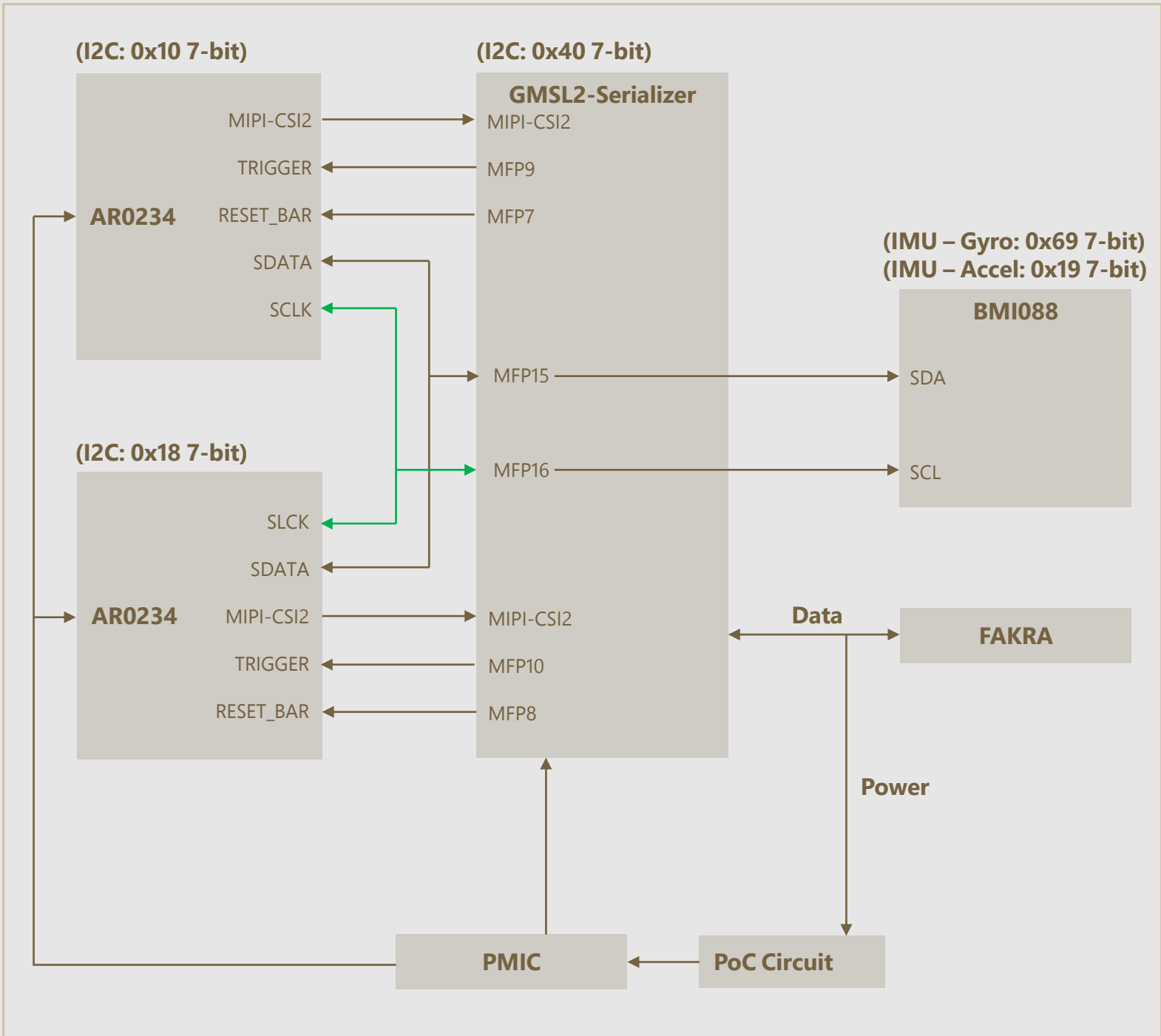

RECOMMENDED ADAPTER BOARDS

LI-JAG-ADP-GMSL2-8CH:

- Nvidia Part#: P3762_A03
- Supports up to 8 cameras
- DeSerializer: Maxim MAX96712
- Compatible with NVIDIA® Jetson AGX Orin™ Developer Kit and LI-AGO-CB carrier board

For more info, refer to:

<https://leopardimaging.com/product/platform-partners/nvidia/nvidia-jetson-orin/agx-orin-camera-kits/li-jag-adp-gmsl2-8ch/>



Connector to
NVIDIA®
Jetson AGX
Orin™
Developer Kit
or LI-AGO-CB

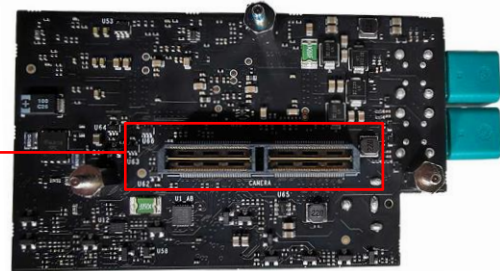

E3653_A03:

- Supports up to 4 cameras
- DeSerializer: Maxim MAX96712
- Compatible with NVIDIA® Jetson AGX Xavier™ and AGX Orin™ Developer Kit.

For more info, refer to:

<https://leopardimaging.com/product/accessories/adapters-carrier-boards/for-nvidia-jetson/e3653-a03/>

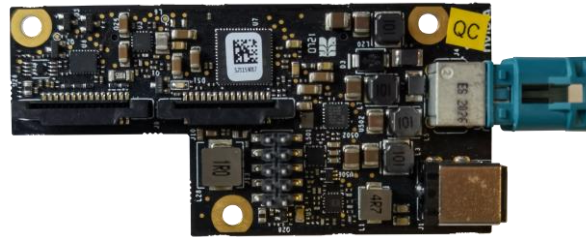

Connector to
NVIDIA®
Jetson AGX
Xavier™ and
AGX Orin™
Developer Kit

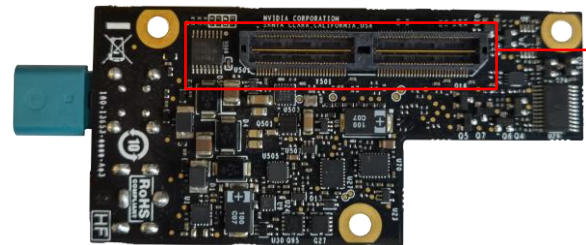

USB3.0 CAMERA KIT

LI-GMSL2-USB



Top View

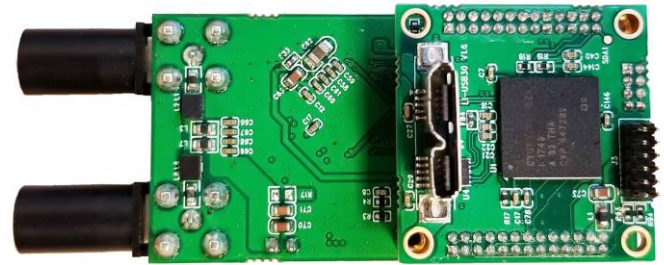

Bottom View

LI-AR0234CS-ST100-GM2C-120H can connect to LI-GMSL2-USB as a USB 3.0 camera.

Part#: **LI-USB30-AR0234CS-ST100-GM2C-120H**

SPECIFICATIONS

- USB 3.0 Super Speed support
- UVC compliant
- Global shutter
- Allows customization
- 12 VDC power supply for camera
- Weight: ~ 251 g
- Single Coax Cable transmits up to 12 meters PoC (Power over Cable)
- Power consumption: 86 mA @ 12 VDC
- Resolution: 2 * (1920 × 1200) @ 7.9 fps
- Compatible with Windows, Linux OS and other OS which have UVC drivers

NOTE: LI-AR0234CS-ST100-GM2C-120H syncs RAW images output side by side (no depth processing function)



BOM

#	Items	QTY
1	LI-AR0234CS-ST100-GM2C-120H	1
2	LI-GMSL2-USB	1
3	3-Meter Fakra Cable	1
4	12 VDC Power Supply	1
5	USB3.0 Cable	1

SDK SUPPORTED

- Camera Tool Source Code in C#
- Capture & Display
- Register Access Function

● REVISION HISTORY

Revision	Description	Release Date
0.1	Initial draft.	14 Jun 2024
0.2	Updated 2D dimensions, weight, size, IP rating, Operating Temp and Storage Temp.	18 Jul 2024

910 Auburn Ct, Fremont, CA 94538, USA

Phone: +1-408-263-0988

Fax: +1-408-217-1960

Email: sales@leopardimaging.com

Website: www.leopardimaging.com

