



LEOPARD
IMAGING

LI-OV2311-VCSEL-GMSL2-055H



Address:

910 Auburn Ct
Fremont, CA 94538
USA



Phone:

+1 (408)263-0988

Fax:

+1 (408)217-1960



Sales:

sales@leopardimaging.com

Support:

support@leopardimaging.com

INTRODUCTION

The LI-OV2311-VCSEL-GMSL2-055H is equipped with OmniVision 2MP CMOS image sensor OV2311, Maxim serializer MAX96717F and VCSEL. This camera outputs 1600 x 1300 RAW image data.

SPECIFICATIONS

Sensor	OmniVision CMOS Image Sensor OV2311
Optical Format	1/2.9"
Resolution	1600 (H) x 1300 (V) (active pixels)
Pixel Size	3.0 x 3.0 μ m
Output Format	10-bit RAW data
Color / Mono	Monochrome
Maximum Frame Rate	60 fps @ 1600 x 1300
Shutter	Global shutter
Serializer	Maxim MAX96717F
Power Supply Range	10 ~ 19 VDC
ISP	Not included
VCSEL	Included
FAKRA Connector	FAKRA Z TYPE
IP Rating	IP52
Power Consumption	131 mA @ 12 VDC (1600 x 1300 @ 60 fps)
Operating Temp	-40°C ~ +85°C
Storage Temp	-40°C ~ +85°C
Weight	~ 80 g
Part#	LI-OV2311-VCSEL-GMSL2-055H

APPLICATIONS

- In Cabin Automotive
 - ◆ Gesture Recognition
 - ◆ Iris Scanning
 - ◆ Head Roll
 - ◆ Eye Tracking
 - ◆ Augmented Reality
 - ◆ Machine Vision

LENS SPECIFICATIONS

Focal Length	4.58 mm \pm 5%
Aperture, F/#	1.8 \pm 0.1
Field of View (FOV)	55.3° \pm 1° horizontal
	45.6° \pm 1° vertical
	70° \pm 1.5° diagonal
Optical Distortion	(-5.2 \pm 3)% @ D FOV
Relative Illumination	(63 \pm 5)% @ D FOV
IR Filter	940 nm IR filter
Lens Mount	M8 x P0.35

VCSEL SPECIFICATIONS

Wavelength	940 nm
Field of Illumination (FOI)	59° horizontal
	42° vertical
QTY on Camera	1



DIMENSIONS

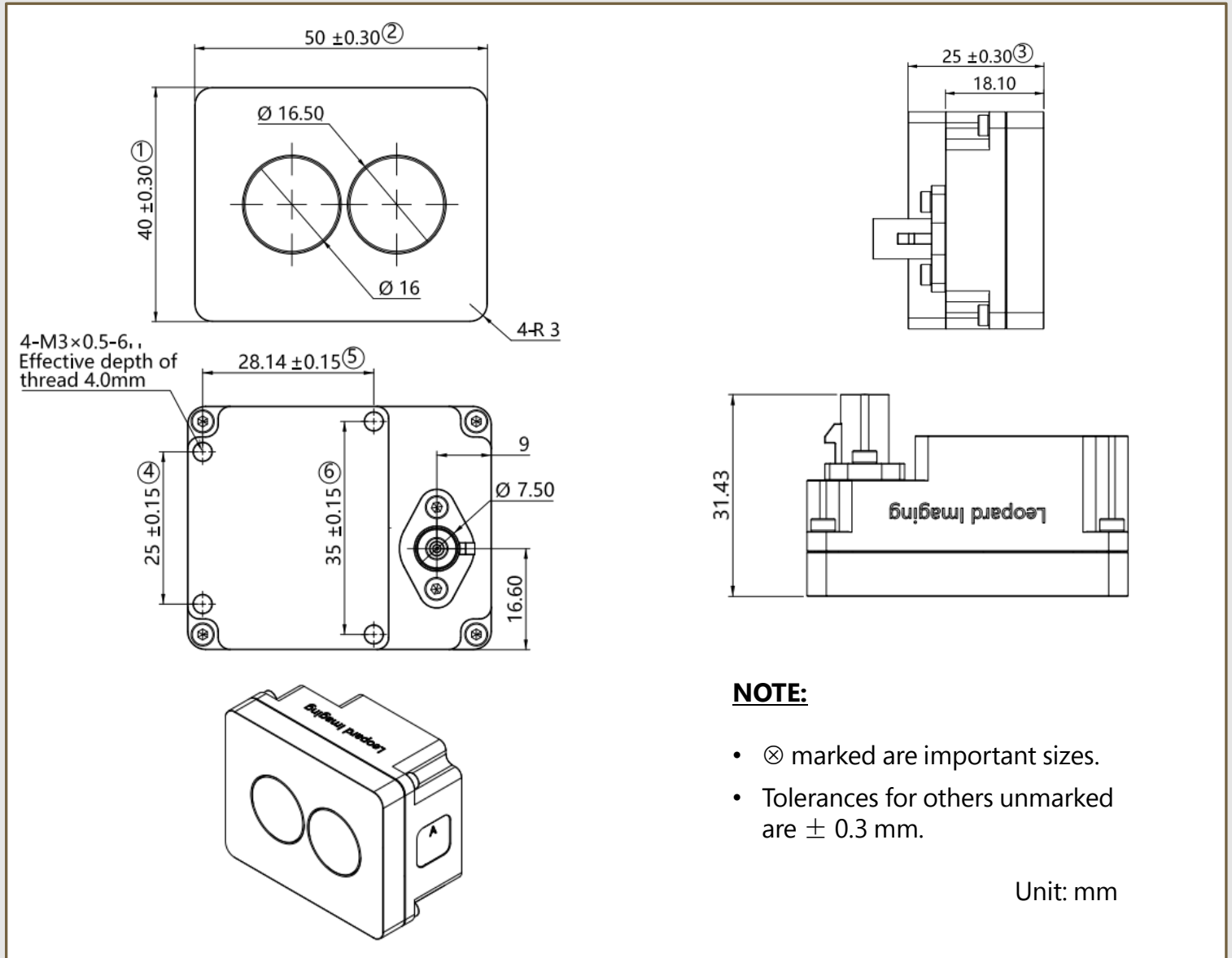

DEFAULT IMAGING DIRECTION

- The logo "Leopard Imaging" is on the TOP.

TOP (Default Imaging Direction)

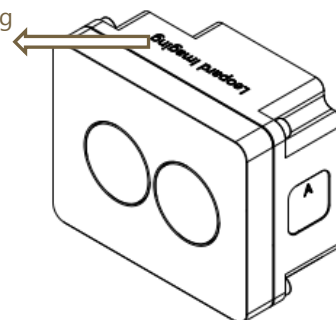

SYSTEM BLOCK DIAGRAM

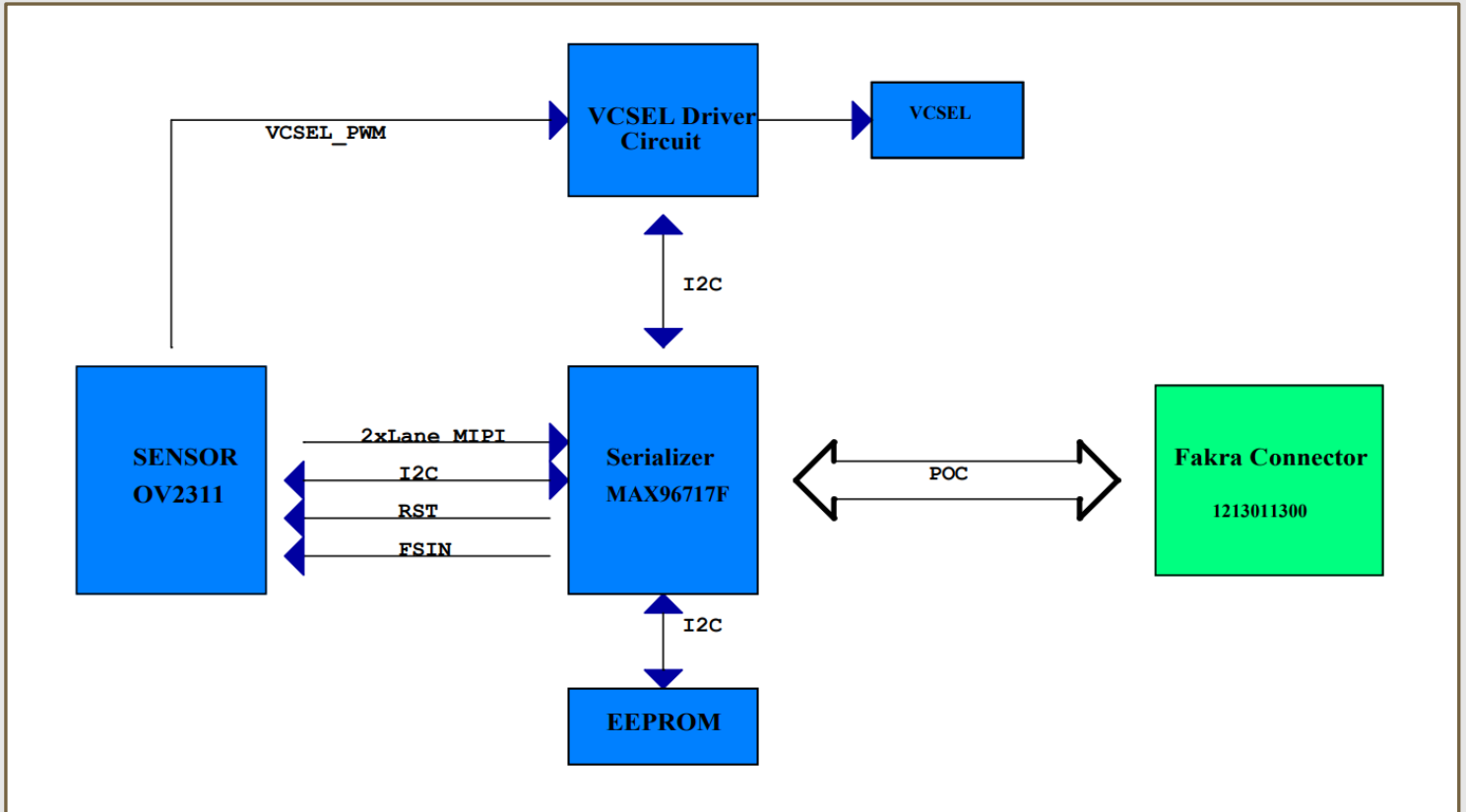

POWER BLOCK DIAGRAM

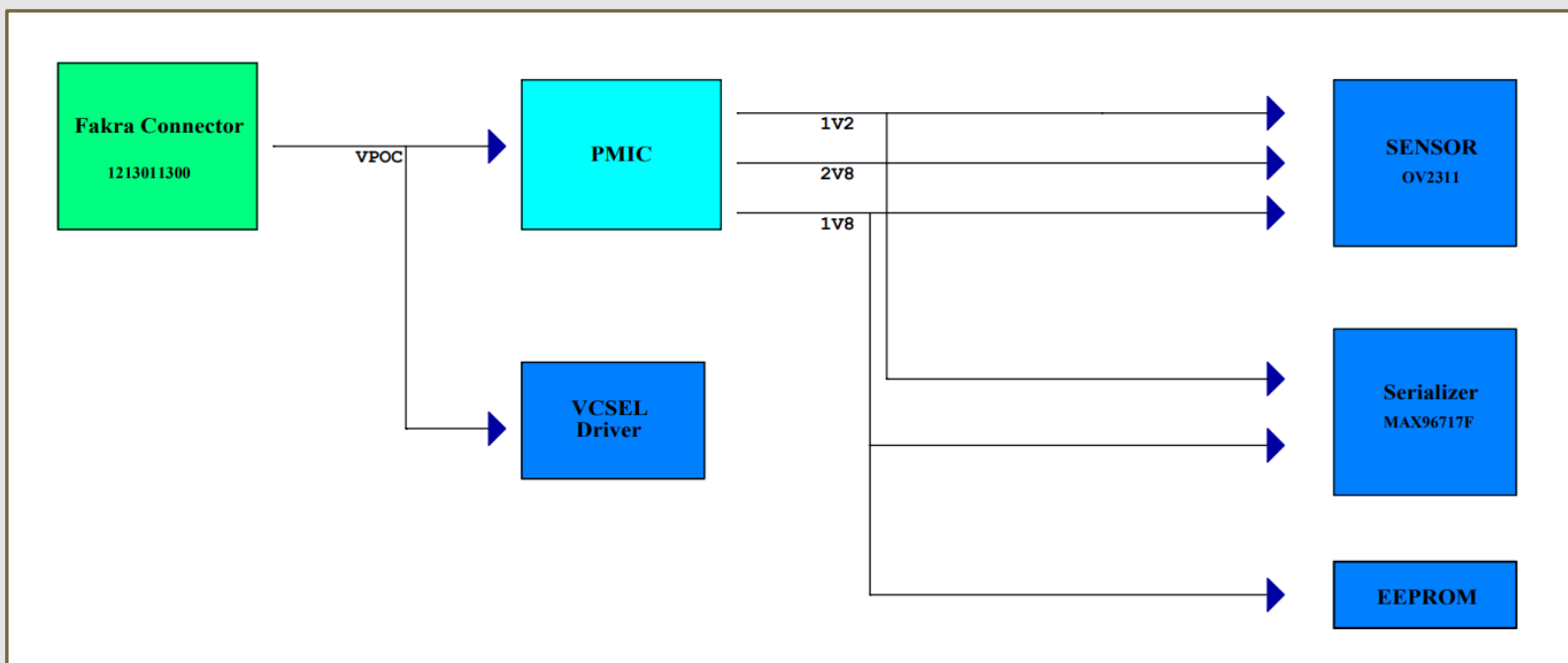

USB3.0 CAMERA KIT

LI-GMSL2-USB



Top View

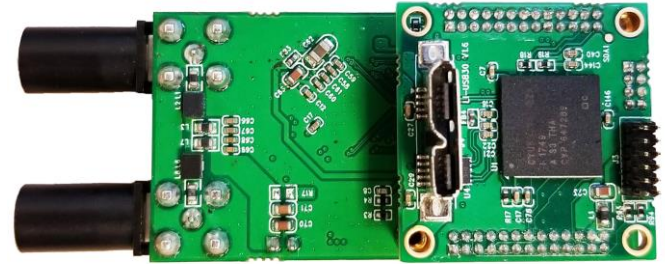

Bottom View

LI-OV2311-VCSEL-GMSL2-055H can connect to LI-GMSL2-USB as a USB 3.0 camera.

Part#: **LI-USB30-OV2311-VCSEL-GMSL2-055H**

SPECIFICATIONS

- USB 3.0 Super Speed support
- UVC compliant
- Global shutter
- Allows customization
- 12 VDC power supply for camera
- Weight: ~ 372 g
- Single Coax Cable transmits up to 12 meters PoC (Power over Cable)
- Resolution: 1600 x 1300 @ 60 fps
- Compatible with Windows, Linux OS and other OS which have UVC drivers



BOM

#	Items	QTY
1	LI-OV2311-VCSEL-GMSL2-055H	1
2	LI-GMSL2-USB	1
3	3-Meter Fakra Cable	1
4	12 VDC Power Supply for Camera	1
5	USB3.0 Cable	1

SDK SUPPORTED

- Camera Tool Source Code in C#
- Capture & Display
- Register Access Function

- REVISION HISTORY

Revision	Description	Release Date
1.0	First release.	08 May 2023

910 Auburn Ct, Fremont, CA 94538, USA

Phone: +1 (408)263-0988

Fax: +1(408)217-1960

Email: sales@leopardimaging.com

Website: www.leopardimaging.com

