



LEOPARD
IMAGING

LI-IMX304-GMSL2



Address:

910 Auburn Ct
Fremont, CA 94538
USA



Phone:

+1 (408)263-0988

Fax:

+1 (408)217-1960



Sales:

sales@leopardimaging.com

Support:

support@leopardimaging.com

INTRODUCTION

The LI-IMX304-GMSL2 is equipped with Sony 17.6 mm CMOS image sensor IMX304 and Maxim GMSL2 serializer MAX9295A/B. This camera outputs 4112 x 3008 RAW data.

KEY FEATURES

Sensor	Sony Diagonal 17.6 mm CMOS Image Sensor IMX304LQR
Optical Format	1.1"
Resolution	4112 (H) x 3008 (V) (active pixels)
Pixel Size	3.45 x 3.45 μm
Data Format	RAW data
Color / Mono	Color sensor
Shutter	Global shutter
Serializer	Maxim MAX9295A/B
FPGA	Included for signal conversion from LVDS to MIPI
Power Supply Range	9 ~ 19 VDC
Connector	FAKRA Z TYPE
Power Consumption	< 140 mA @ 12 VDC
Operating Temp	-30°C ~ +75°C
Storage Temp	-40°C ~ +85°C
Weight (without Lens)	~ 81 g
Part#	LI-IMX304-GMSL2

APPLICATIONS

- ITS cameras

LENS SPECIFICATIONS (OPTIONAL)

Focal Length	6 mm
Aperture, F/#	1.8 ~ 16
Field of View (FOV)	105° horizontal
TTL	95.3 mm
TV Distortion	< 2.3%
Mount	C-Mount

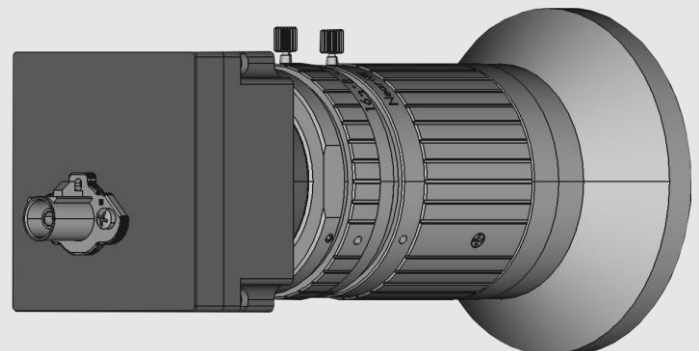
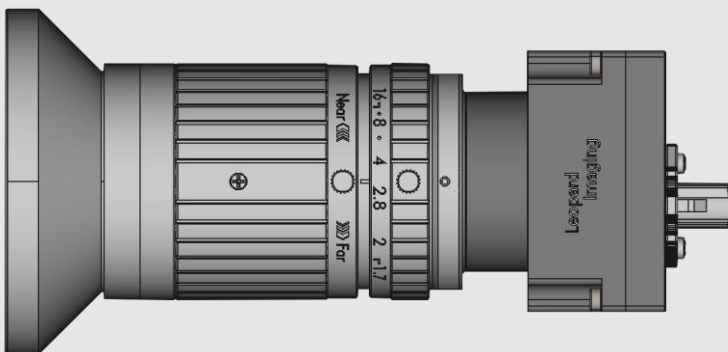
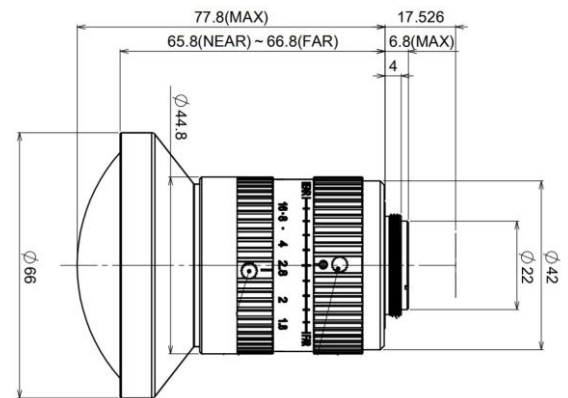

PINOUT CONNECTIONS

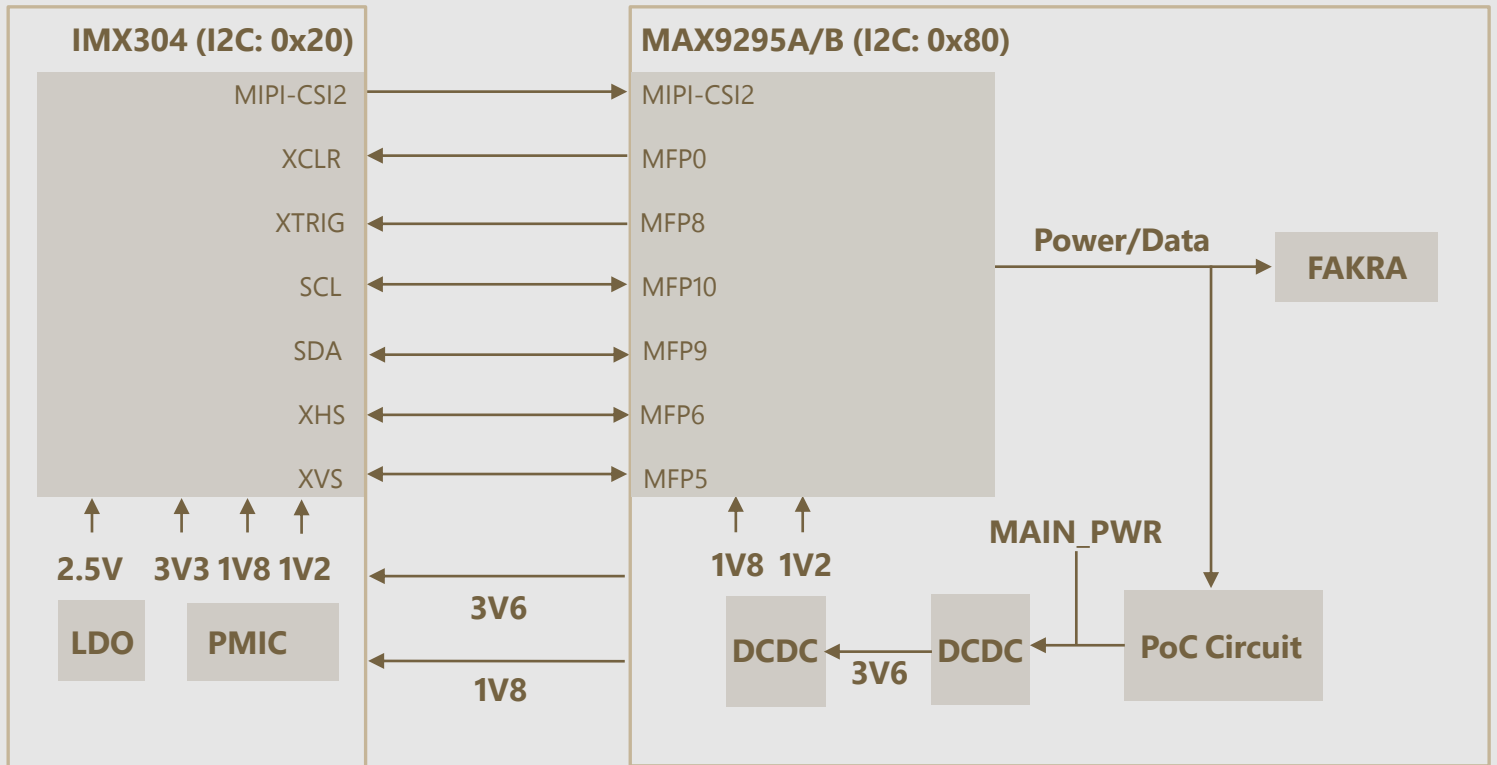

DIMENSIONS (WITH OPTIONAL LENS)

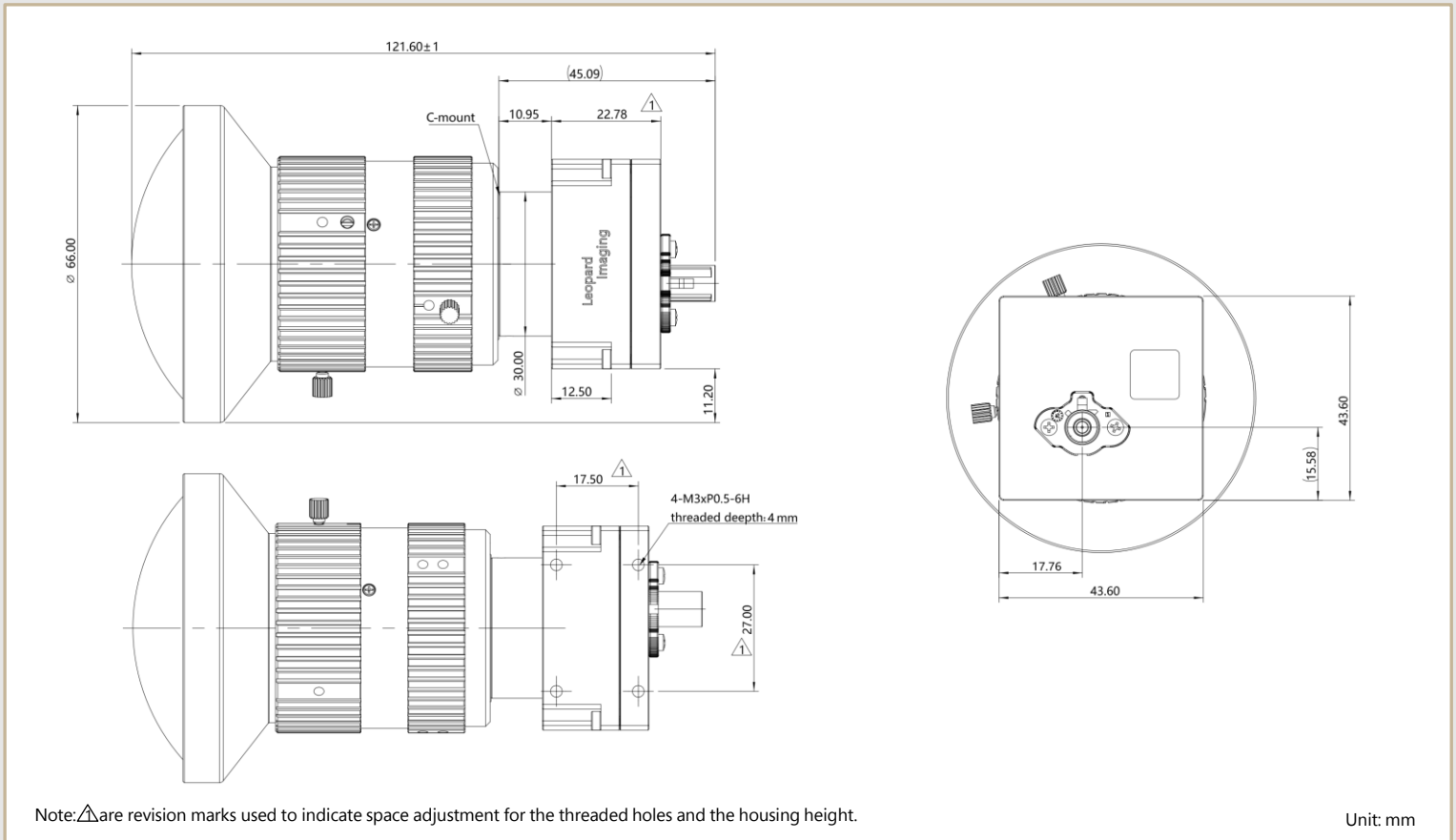

USB3.0 CAMERA KIT

LI-GMSL2-USB-BOX



Front View



Side View

LI-IMX304-GMSL2 can connect to LI-GMSL2-USB-BOX as a USB 3.0 camera.

Part#: **LI-USB30-IMX304-GMSL2**

KEY FEATURES

- USB 3.0 Super Speed support
- UVC compliance
- Global shutter
- Provide customization services
- 12 VDC power supply
- Weight: ~ 280 g
- Single Coax Cable transmit up to 12 meters PoC (Power over Cable)
- Resolution: 4096 x 3018 @ 9fps
- Power consumption: < 140 mA @ 12 VDC
- Support Windows, Linux OS and other OS which include the UVC drivers

BOM

#	Items	QTY
1	LI-IMX304-GMSL2	1
2	LI-GMSL2-USB-BOX	1
3	3-Meter Fakra Cable	1
4	12 VDC Power Supply	1
5	USB3.0 Cable	1



SDK SUPPORTED

- Camera Tool Source Code in C#
- Capture & Display

● REVISION HISTORY

Revision	Description	Release Date
1.0	First release.	08 Aug 2020
1.1	Updated dimensions, serializer and added BOM and FPGA info.	23 Aug 2021
1.2	Deleted lens model info.	09 Aug 2023

910 Auburn Ct, Fremont, CA 94538, USA

Phone: +1-408-263-0988

Fax: +1-408-217-1960

Email: sales@leopardimaging.com

Website: www.leopardimaging.com

