

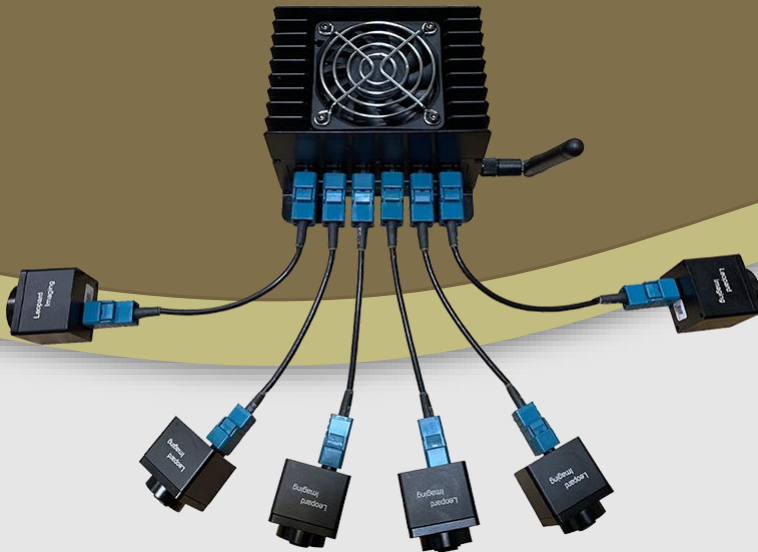

**LEOPARD**  
IMAGING

# LI-TX2B-IMX390-GMSL2-xxxH-X



**Address:**

910 Auburn Ct  
Fremont, CA 94538  
USA



**Phone:**

+1 (408)263-0988

**Fax:**

+1 (408)217-1960



**Sales:**

[sales@leopardimaging.com](mailto:sales@leopardimaging.com)

**Support:**

[support@leopardimaging.com](mailto:support@leopardimaging.com)

## KEY FEATURES

- NVIDIA® Jetson™ TX2 SOM included
- Supports up to six GMSL2 cameras
- Sony Diagonal 6.67 mm (Type 1/2.7) CMOS RGGB Image Sensor IMX390
- Pixel size: 3.0 x 3.0 μm
- Lens: FOV H 60° / 120° / 200°
- Resolution: 1920 (H) x 1080 (V)
- GMSL2 serializer and De-serializer included
- Connector: FAKRA Z TYPE
- Length of Fakra cable: 3 meters
- Multiple length Fakra cables supported
- M12 lens
- TX2 driver binary and source code included

## APPLICATIONS

- IoT Camera
- Machine Vision
- 1080P Video Applications

## BOM

#	Items	QTY
1	LI-TX2-BOX1-GMSL2	1
2	FAK-SMZSMZ 3M	2, 4 or 6
3	LI-IMX390-GMSL2-xxxH	2, 4 or 6
4	LI-PS12-02	1

## PART#

xxxH refers to 060H, 120H or 200H

2 CAM	LI-TX2B-IMX390-GMSL2-xxxH-D
4 CAM	LI-TX2B-IMX390-GMSL2-xxxH-Q
6 CAM	LI-TX2B-IMX390-GMSL2-xxxH-H

## Ordering Information

● PART#: LI-TX2B-IMX390-GMSL2-xxxH-X

xxxH refers to 060H (FOV H 60°), 120H (FOV H 120°), 200H (FOV H 200°)

LI-IMX390-GMSL2-060H

Lens EFL: 6.0 mm
Aperture, F/#: 1.8
Field of View (FOV): 74.5° (D) / 60.6° (H) / 36.1° (V)
Mount: M12

LI-IMX390-GMSL2-120H	LI-IMX390-GMSL2-200H
	
Lens EFL: 2.8 mm	Lens EFL: 0.95 mm $\pm$ 5%
Aperture, F/#: 2.0	Aperture, F/#: 2.0 $\pm$ 5%
Field of View (FOV): 148° (D) / 122° (H) / 74° (V)	Field of View (FOV): 200° (H)
Mount: M12	Mount: M12

# LI-IMX390-GMSL2-xxxH



## KEY FEATURES

Sensor	Sony Diagonal 6.67 mm CMOS RGGB Image Sensor IMX390
Optical Format	1/2.7"
Resolution	1937 (H) x 1217 (V) (active pixels)
Pixel Size	3.0 x 3.0 $\mu\text{m}$
Data Format	20-bit / 12-bit RAW data
Color / Mono	Color sensor
Lens	FOV H 60° / 120° / 200°
Serializer	Maxim MAX9295A/B
IP Rating	060H / 120H: IP67 200H: IP69K
Power Supply Range	9 ~ 19 VDC
Interface	GMSL2 Serial interface
Operating Temp	-40°C ~ +85°C
Storage Temp	-40°C ~ +85°C
Weight	~ 45 g
Part#	LI-IMX390-GMSL2-xxxH

## DEFAULT IMAGING DIRECTION

- The logo "Leopard Imaging" is on the TOP.

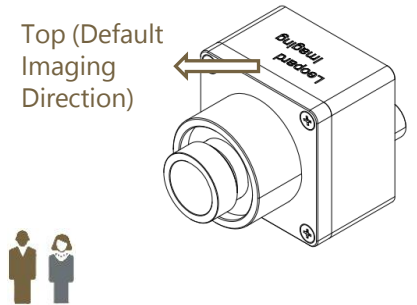

## CABLE CONNECTOR

- Housing Connector: FAKRA Z Type
- Cable Length: 3 meters
- Cable Part#: FAK-SMZSMZ-3M



## LI-IMX390-GMSL2-xxxH

### DIMENSIONS: LI-IMX390-GMSL2-060H

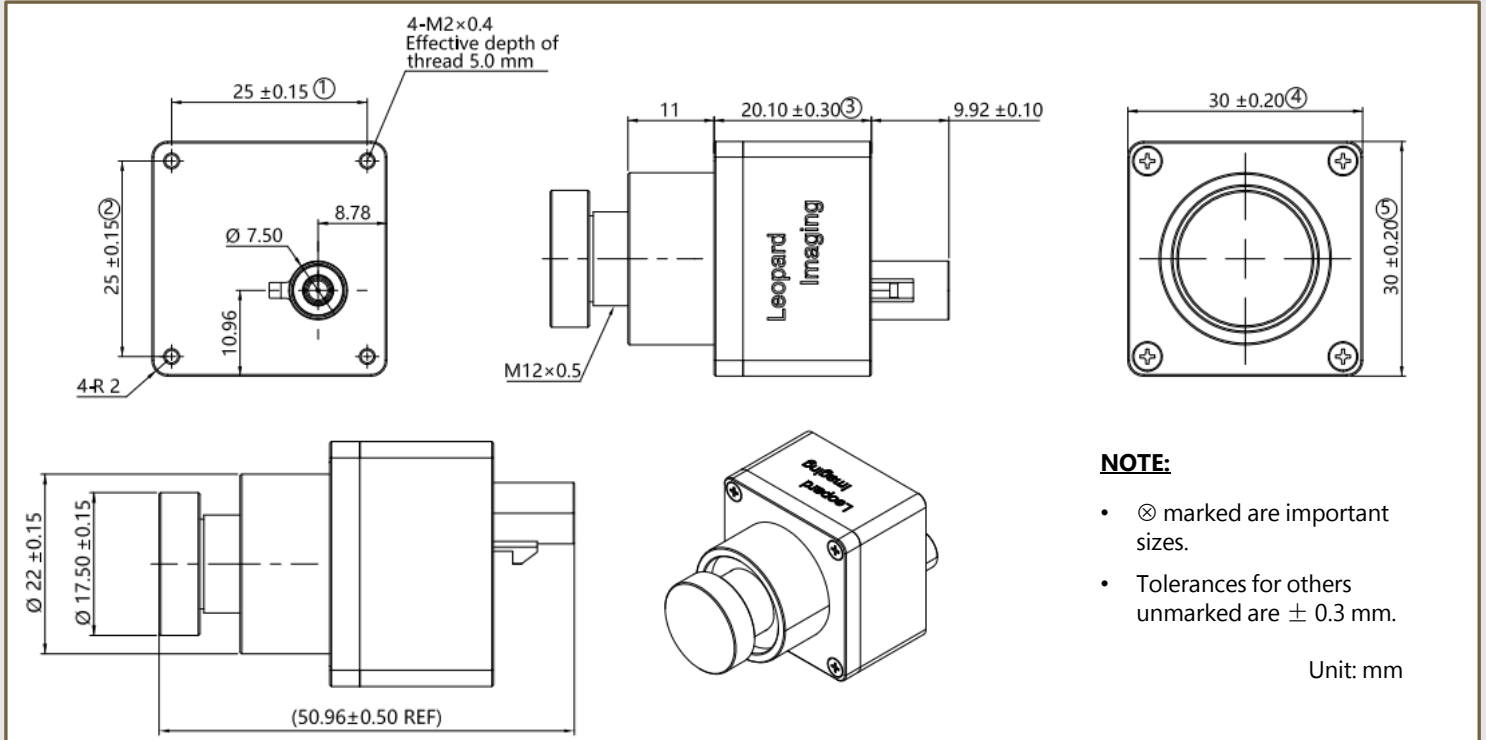

### DIMENSIONS: LI-IMX390-GMSL2-120H

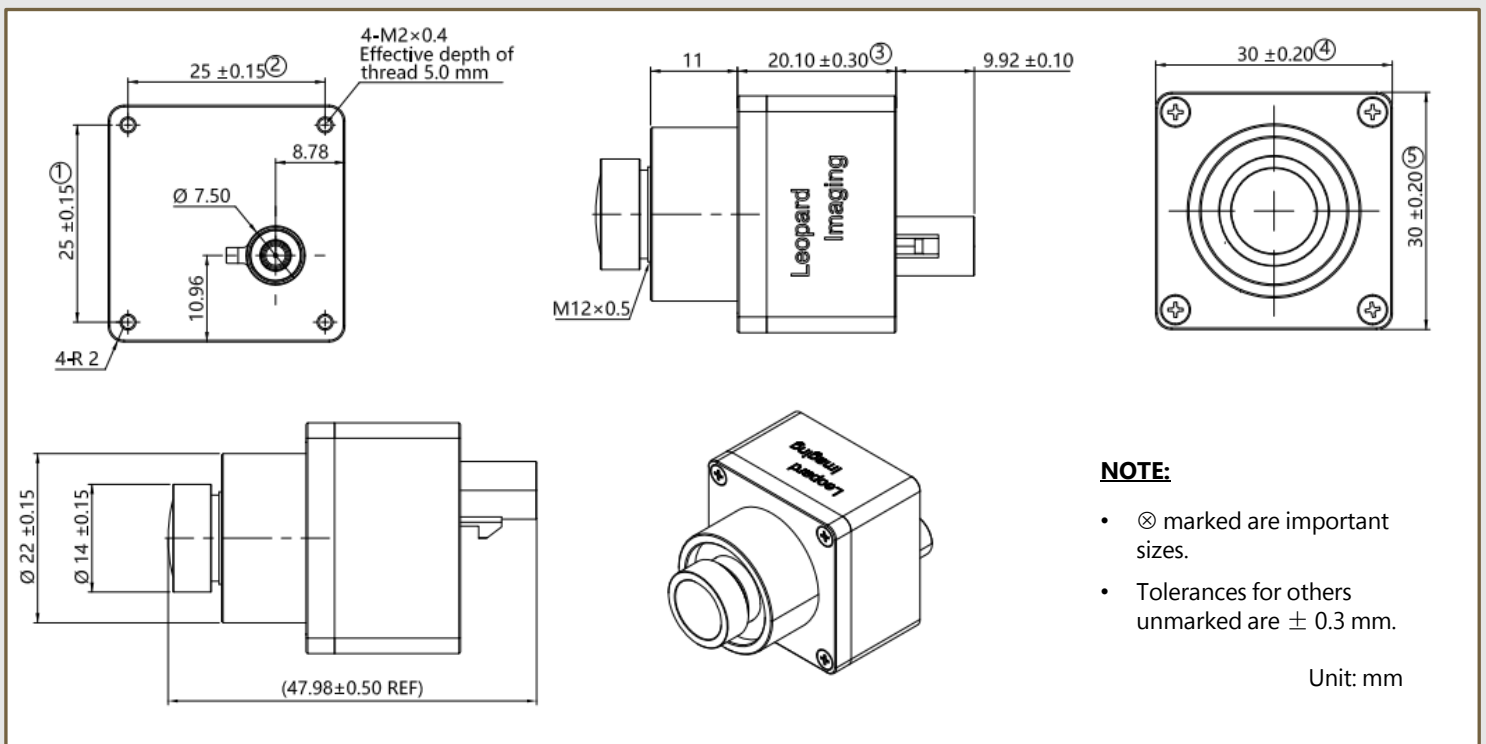

# LI-IMX390-GMSL2-xxxH

## DIMENSIONS: LI-IMX390-GMSL2-200H

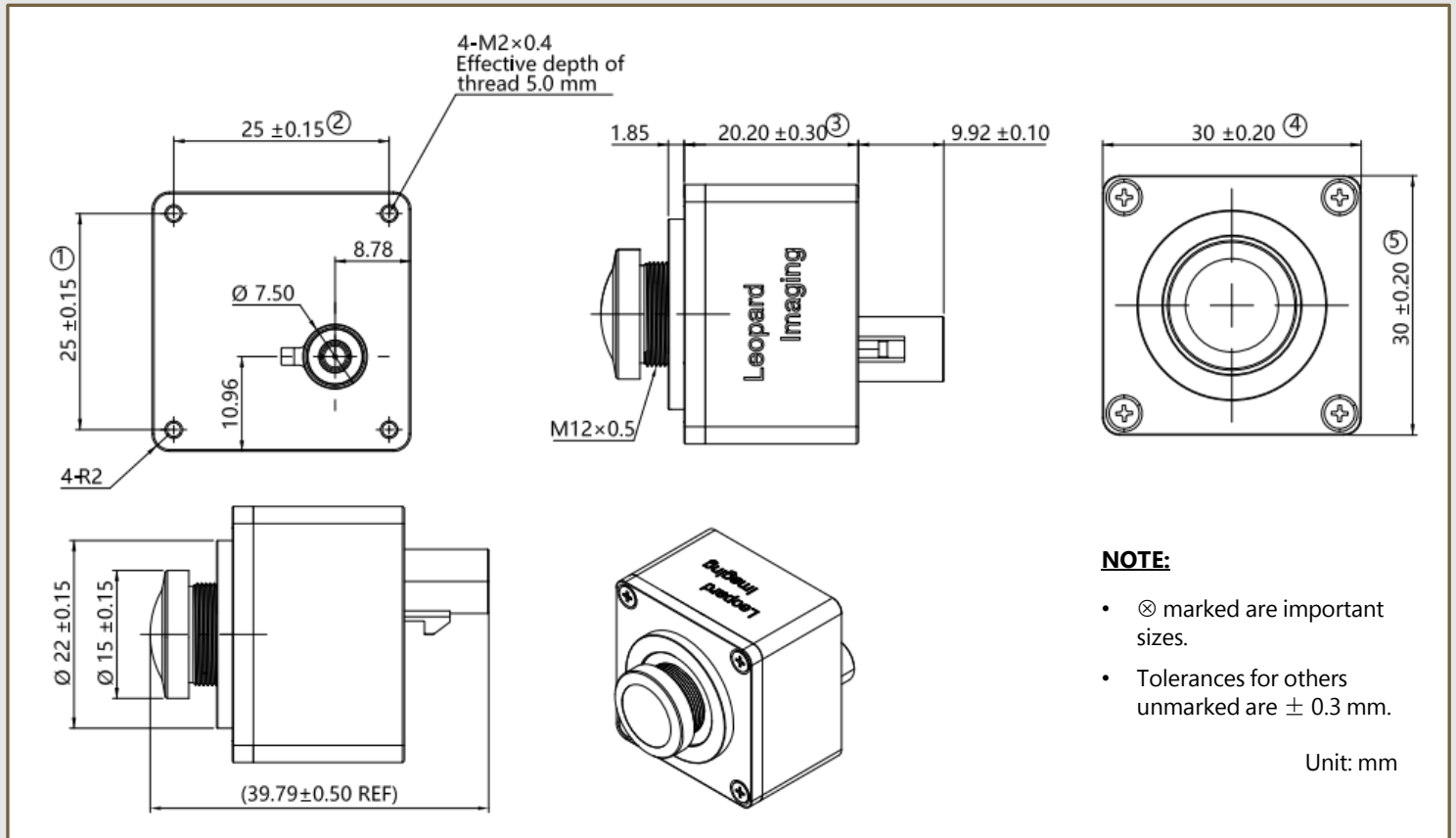

## LI-TX2-BOX1-GMSL2



### TECHNICAL DETAILS

- NVIDIA® Jetson™ TX2 SOM included
- 6 x GMSL2 interfaces
- 1 x Micro SD card interface
- 1 x Micro HDMI connector
- 1 x Power socket (DC 12V)
- 1 x RJ45 Ethernet connector
- 1 x USB 2.0 Micro-B interface
- REC, RST and PWR buttons included
- Heat sink and fan included
- WIFI Antenna included
- Connector: FAKRA Z TYPE
- Includes 4 mounting holes
- Weight: ~ 500 g
- Size: 100 (L) x 100 (W) x 69 (D) mm (without WIFI Antenna)
- Part#: **LI-TX2-BOX1-GMSL2**

# LI-TX2-BOX1-GMSL2

## DIMENSIONS (With Box)

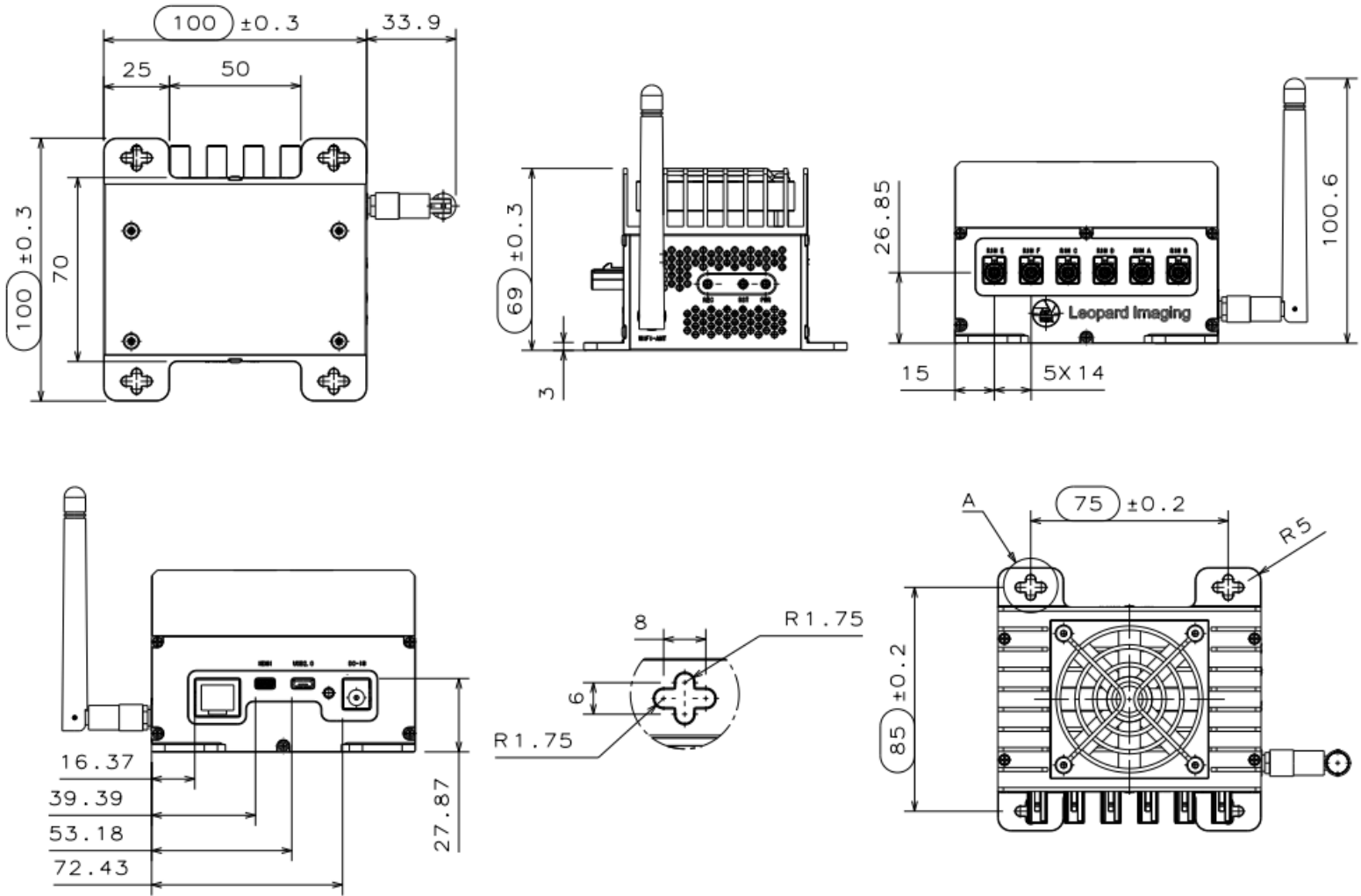

**NOTE:**

- $\text{○}$  marked are important sizes.
- Tolerances for others unmarked are  $\pm 0.3$  mm.

Unit: mm



## ● REVISION HISTORY

Revision	Description	Release Date
1.0	First release.	23 Dec 2018
1.1	Updated lens and related pictures and 2D dimensions.	29 Jan 2023
1.2	Replaced 3D images of 200H lens with actual product pictures.	20 Mar 2023
1.3	Updated 200H IP in "LI-IMX390-GMSL2-xxxH" section and deleted IP in "Ordering Information" section.	27 Dec 2023

910 Auburn Ct, Fremont, CA 94538, USA

Phone: +1-408-263-0988

Fax: +1-408-217-1960

Email: [sales@leopardimaging.com](mailto:sales@leopardimaging.com)

Website: [www.leopardimaging.com](http://www.leopardimaging.com)

