

Key Features

- Compatible with Nvidia® Jetson AGX Xavier™ Developer Kit
- Support one FPDLINKIII camera
- ON SEMI 2.3MP AR0231 RCCB Sensor
- Active pixels: 1928H x 1208V
- Pixel size: 3.0 x 3.0 μm
- Color camera
- Lens: FOV H 60 / 120 / 200
- TI953 FPD-Link III serializer
- Includes De-serializer to convert serial interface to MIPI interface
- Length of Fakra cable: 3 meters
- Support multiple length Fakra cables
- Length of the I-PEX cable: 300mm
- Support M12 lens
- Provide customization services
- Part#:
LI-AR0231-TI953-XAVIER-xxxH

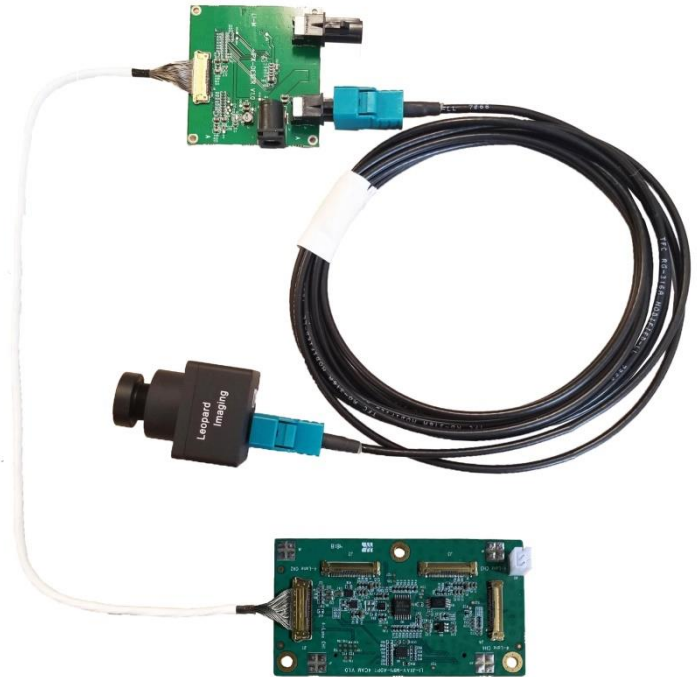

Application

- Automotive ADAS
- 1080p30 video applications
- ADAS + Viewing Fusion

BOM

Nvidia Jetson Xavier Developer Kit not included

#	Items	QTY
1	LI-AR0231-FPDLINKIII-xxxH	1
2	FAK-SMZSMZ 3M	1
3	LI-TI954-IPX-DESER	1
4	FAW-1233-03 cable	1
5	LI-JXAV-MIPI-ADPT-4CAM	1
6	LI-PS12-01	1

Compatible with Nvidia Jetson AGX Xavier Developer Kit

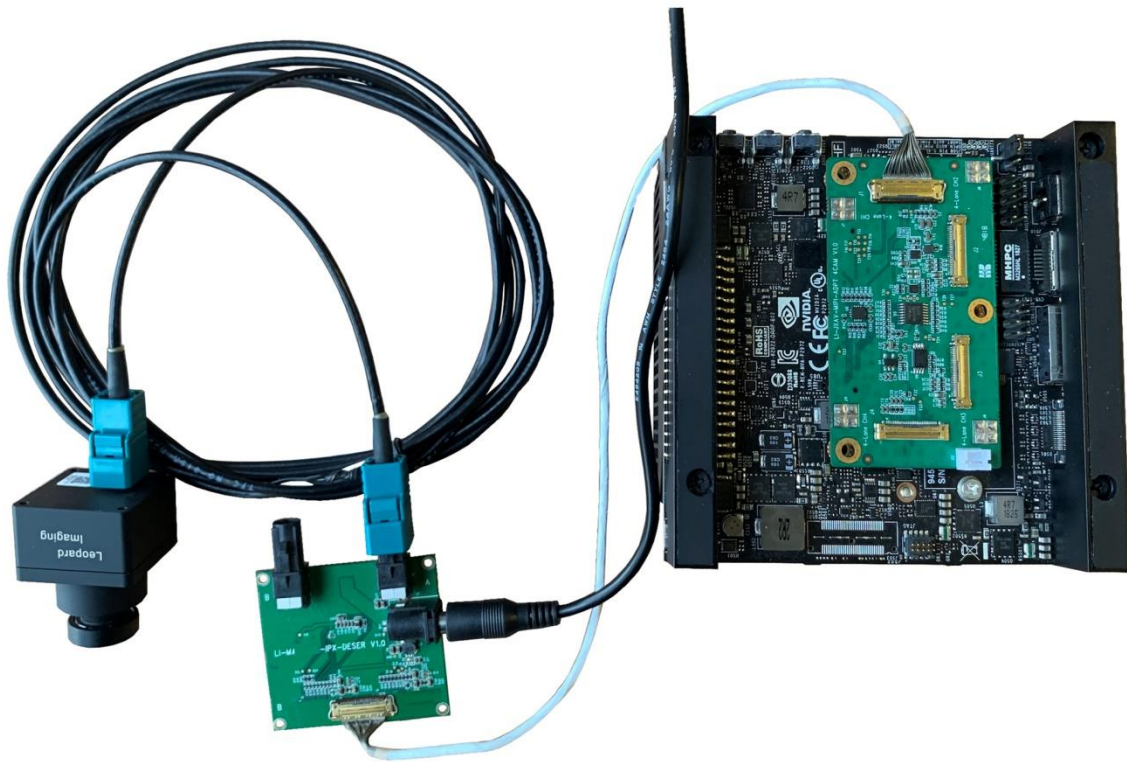

Leopard Imaging Inc.

910 Auburn Ct, Fremont, CA 94538, USA
Phone: +1-408-263-0988
Fax: +1-408-217-1960
Email: sales@leopardimaging.com
Website: www.leopardimaging.com

Dimensions

LI-AR0231-FPDLINKIII-xxxH (without lens)

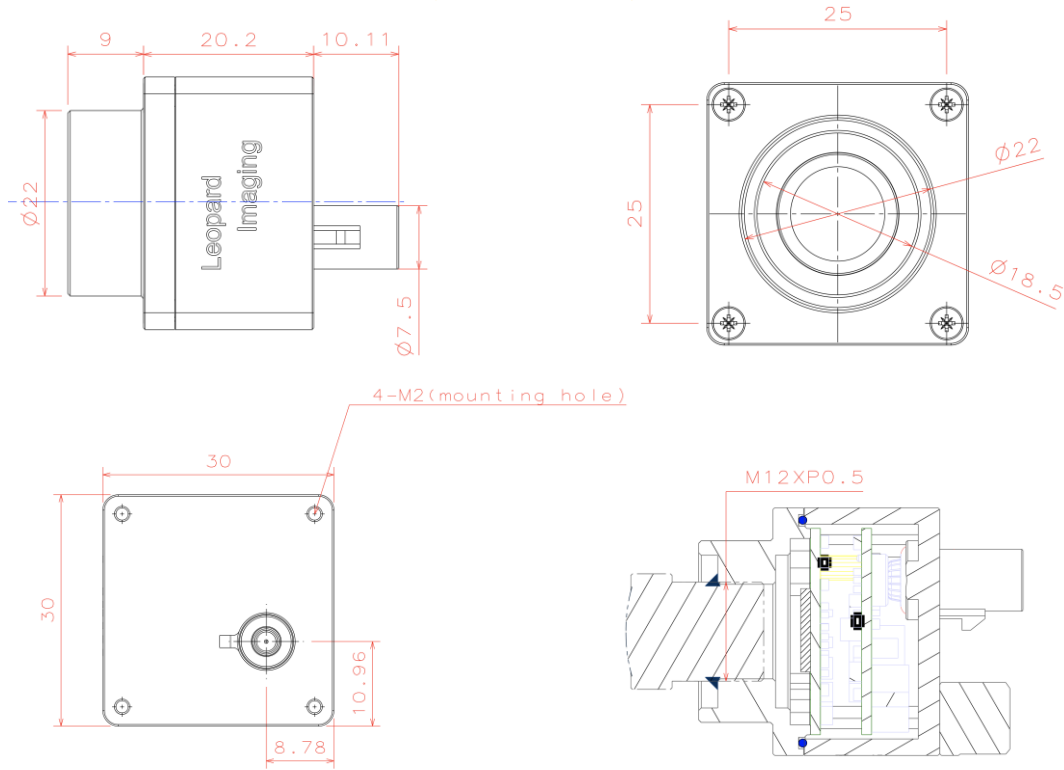

LI-JXAV-MIPI-ADPT-4CAM

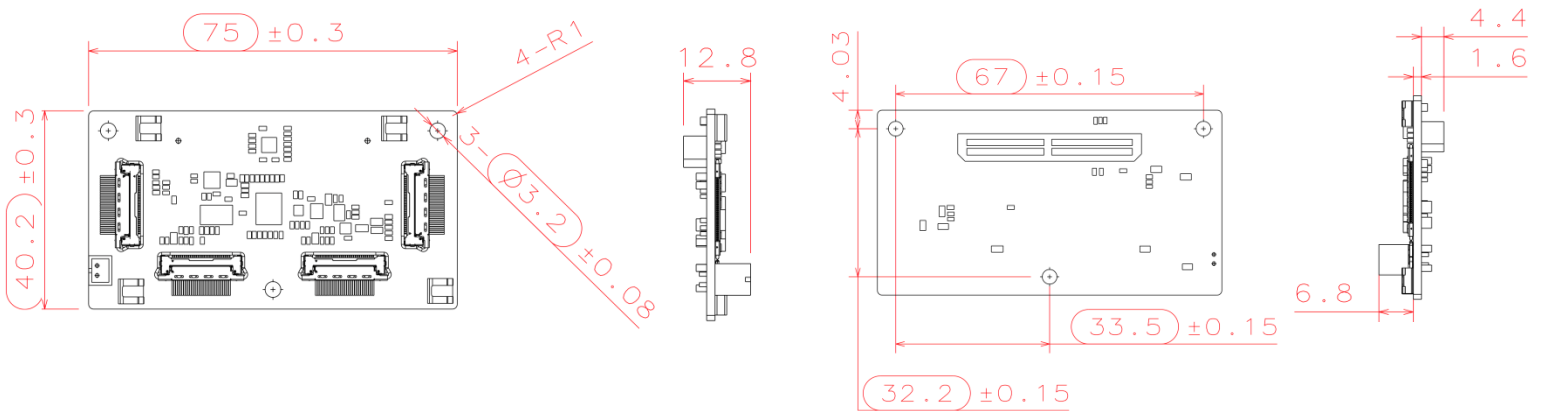

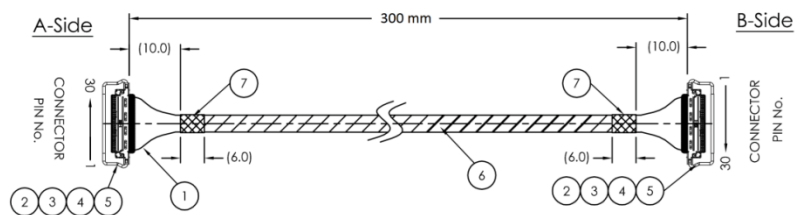

FAW-1233-03

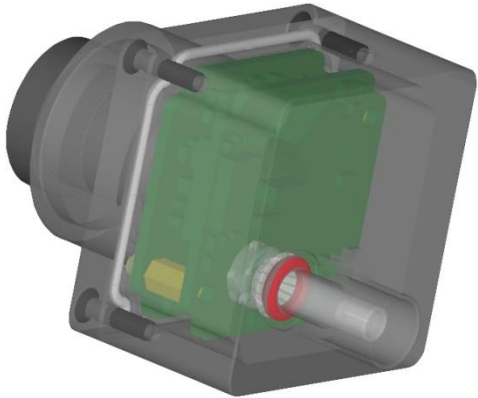

Leopard Imaging Inc.

910 Auburn Ct, Fremont, CA 94538, USA
 Phone: +1-408-263-0988
 Fax: +1-408-217-1960
 Email: sales@leopardimaging.com
 Website: www.leopardimaging.com

Camera Spec	
Image Sensor	ON SEMI 2.3MP AR0231 RCCB Sensor
Optical format	1/2.7"
Number of active pixels	1928 (H) x 1208 (V)
Pixel size	3.0 (H) x 3.0 μm (V)
Color or Mono	Color
Interface	TI953 FPD-Link III Serial interface
Lens mount	M12
Weight	45 g
Operation Temp	-40°C ~ +105°C
Storage Temp	-40°C ~ +125°C
Water proof : IP67 (Up to IP69K) Lens must be glued	
<ul style="list-style-type: none">▪ Metal Housing▪ Water-proof M12 lens▪ Sealed Gasket (White)▪ Sealed O-ring (Red)	
Cable Connector	
<ul style="list-style-type: none">▪ Housing Connector- FAKRA Z Type▪ Cable length: 3 meters Support single Coax Cable transmit up to 15 meters▪ Cable Part#: FAK-SMZSMZ-0008 FAKRA type connectors	





Lens Information

Part#: LI-AR0231-TI953-XAVIER-xxxH

Note:

xxxH - 060H: FOV H 60°
 120H: FOV H 120°
 200H: FOV H 200°

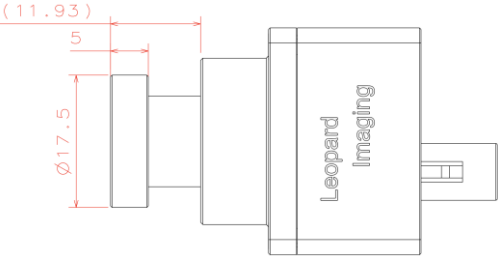
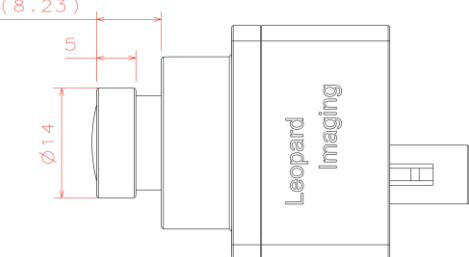
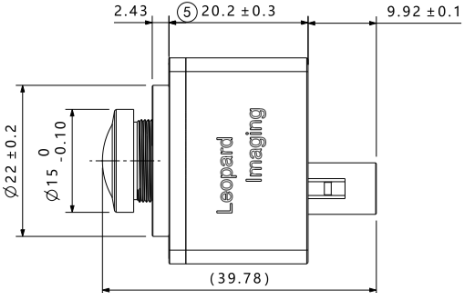
LI-AR0231-FPDLINKIII-060H	LI-AR0231-FPDLINKIII-120H	LI-AR0231-FPDLINKIII-200H
		
<p>Lens EFL: 6.0 mm FOV(D): 74.5° FOV(H): 60.6° FOV(V): 36.1°</p>	<p>Lens EFL: 2.8 mm FOV(D): 148° FOV(H): 122° FOV(V): 74°</p>	<p>Lens EFL: 0.95 mm ± 5% FOV(H): 200°</p>
		



Leopard Imaging Inc.

910 Auburn Ct, Fremont, CA 94538, USA
 Phone: +1-408-263-0988
 Fax: +1-408-217-1960
 Email: sales@leopardimaging.com
 Website: www.leopardimaging.com

LI-JXAV-MIPI-ADPT-4CAM

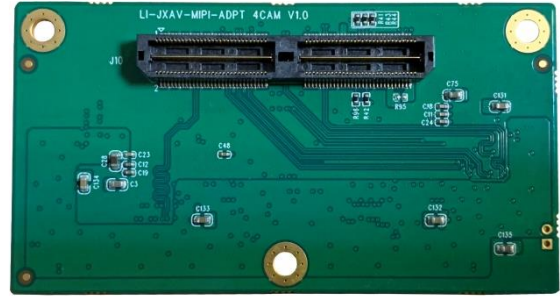

Interfaces

Interface J1

- Part#: 20525-030E-02
- Number of Positions: 30
- Pitch: 0.4mm
- Mating I-PEX cable: FAW-1233-03 (300mm)

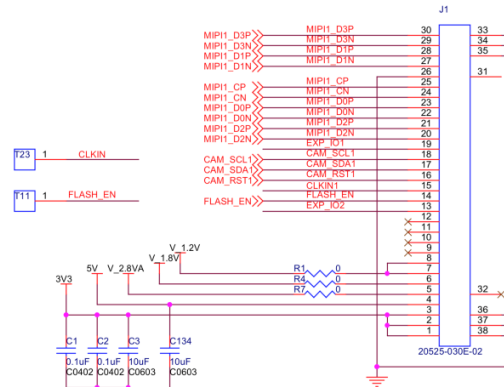

Interface J2

- Part#: 20525-030E-02
- Number of Positions: 30
- Pitch: 0.4mm
- Mating I-PEX cable: FAW-1233-03 (300mm)

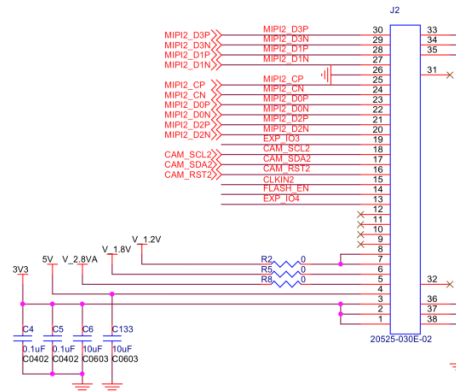

Interface J3

- Part#: 20525-030E-02
- Number of Positions: 30
- Pitch: 0.4mm
- Mating I-PEX cable: FAW-1233-03 (300mm)

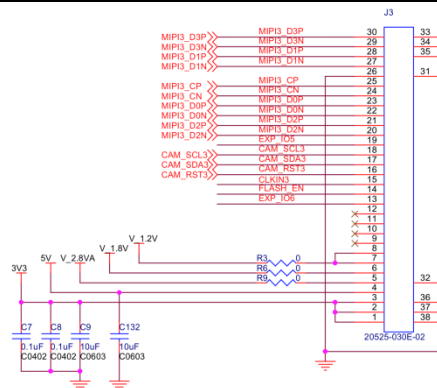

Leopard Imaging Inc.

910 Auburn Ct, Fremont, CA 94538, USA
 Phone: +1-408-263-0988
 Fax: +1-408-217-1960
 Email: sales@leopardimaging.com
 Website: www.leopardimaging.com

Interface J4

- Part#: 20525-030E-02
- Number of Positions: 30
- Pitch: 0.4mm
- Mating I-PEX cable: FAW-1233-03 (300mm)

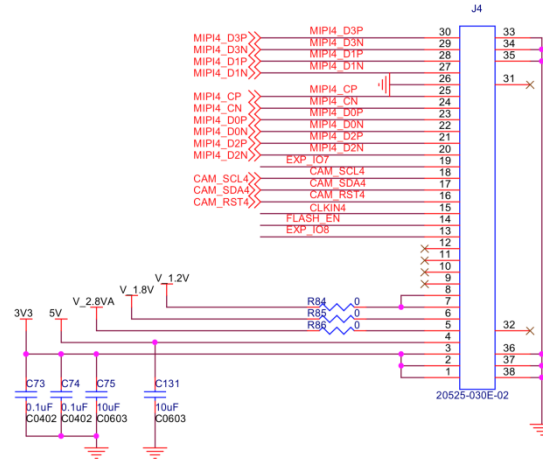

Interface J5

- Part#: 0894000220
- Number of Positions: 2
- Pitch: 2mm

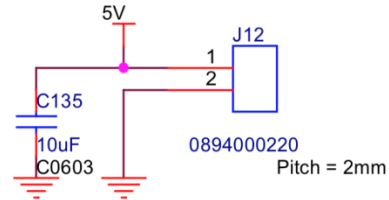

Interface J10

- Part#: QTH-060-01-L-D-A
- Number of Positions: 120
- Number of Rows: 2
- Pitch: 0.5 mm

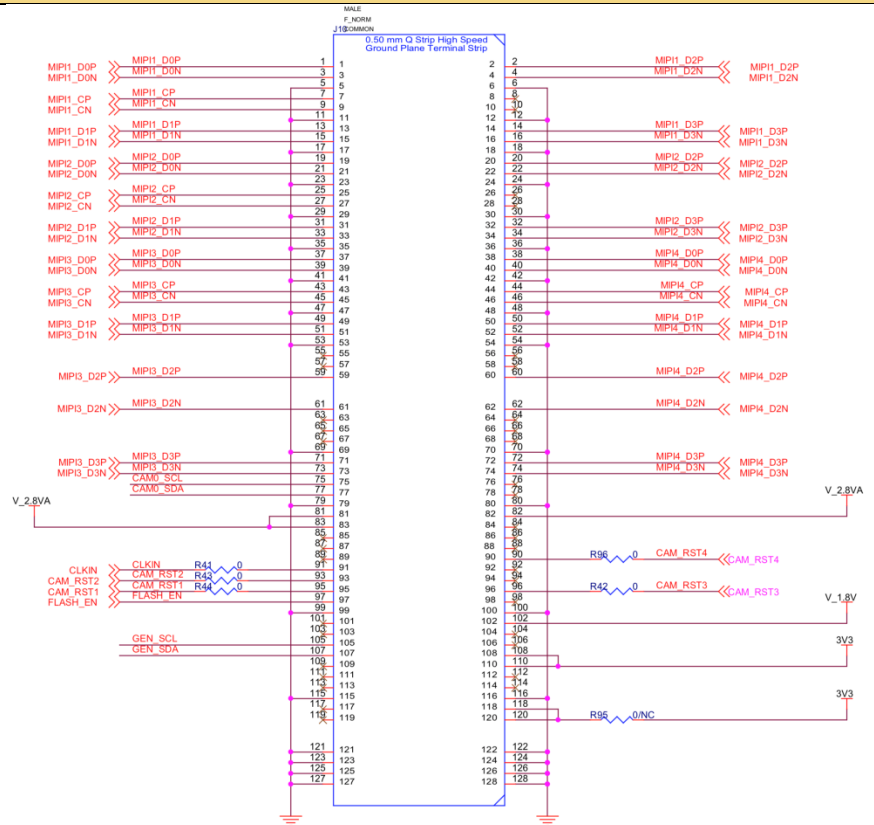

Leopard Imaging Inc.

910 Auburn Ct, Fremont, CA 94538, USA
 Phone: +1-408-263-0988
 Fax: +1-408-217-1960
 Email: sales@leopardimaging.com
 Website: www.leopardimaging.com

LI-TI954-IPX-DESER

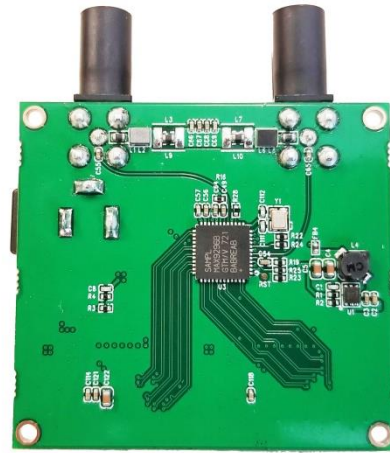

Interfaces

Interface J7

- Part#: PJ-002A
- Power Supply: 12V DC

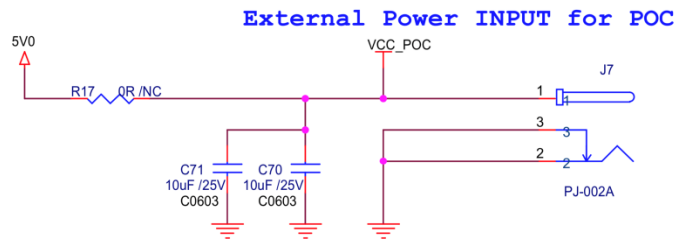

Interface J4

- Part#: 20525-030E-02C
- Number of Positions: 30
- Pitch: 0.4mm
- Mating I-PEX cable: FAW-1233-03 (300mm)

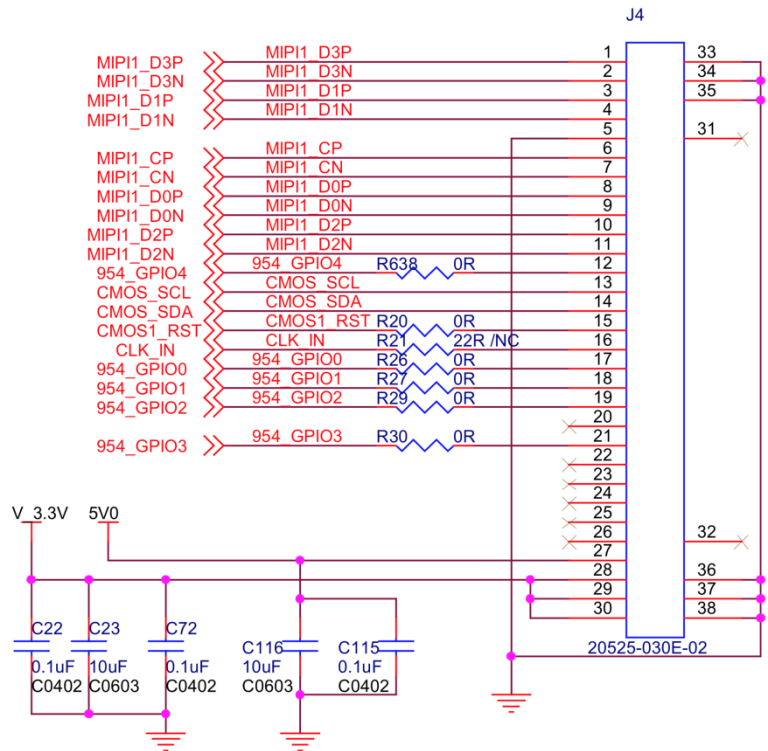

Leopard Imaging Inc.

910 Auburn Ct, Fremont, CA 94538, USA
 Phone: +1-408-263-0988
 Fax: +1-408-217-1960
 Email: sales@leopardimaging.com
 Website: www.leopardimaging.com

De-Serializer

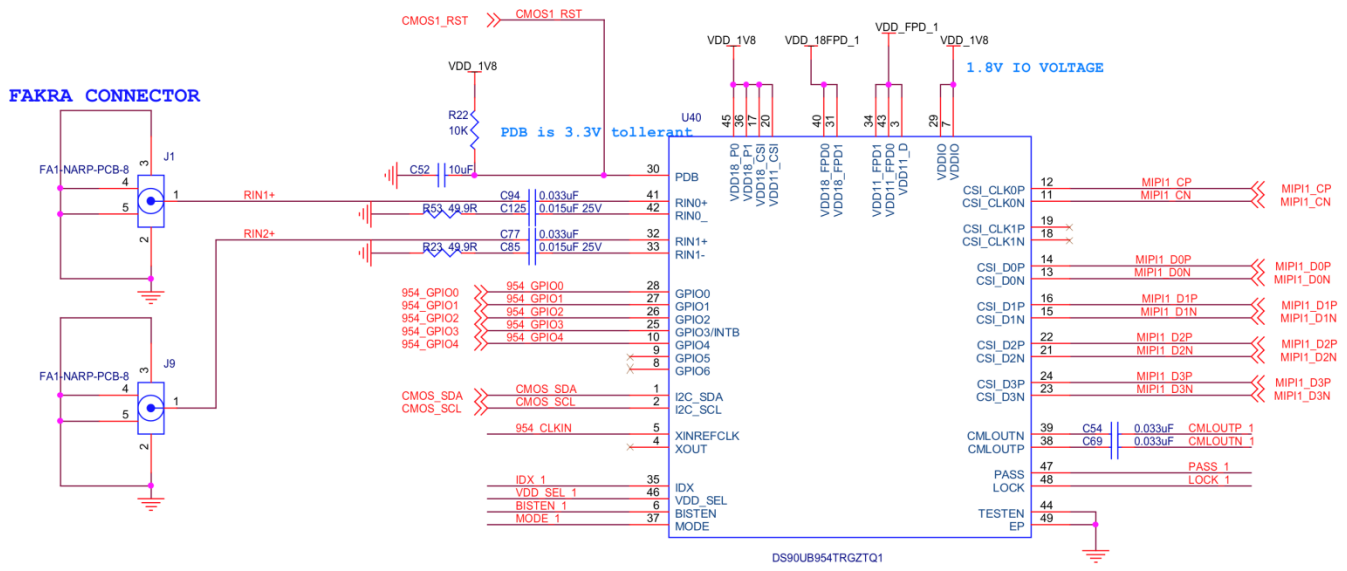

Leopard Imaging Inc.

910 Auburn Ct, Fremont, CA 94538, USA
 Phone: +1-408-263-0988
 Fax: +1-408-217-1960
 Email: sales@leopardimaging.com
 Website: www.leopardimaging.com

Revision History

Revision	Description	Release Date
1.0	First Release	22. Apr. 2019
1.1	Deleted lens model info.	10. Aug. 2023

