



LEOPARD
IMAGING

LI-IMX327-MIPI-CS

Data Sheet

Rev. 1.2

Key Features

- Sony Diagonal 6.46 mm (Type 1/2.8) 2MP CMOS Image Sensor IMX327
- Active pixels: 1937 (H) x 1097 (V)
- Pixel size: 2.9 x 2.9 μm
- Color sensor
- Interface: MIPI output
- Support CS lens
- Module Size: 38 x 38 mm
- Weight: ~ 56 g
- Part#: **LI-IMX327-MIPI-CS**



Lens Spec

- Focal Length: 5.0 mm
- Aperture, F/#: 2.2
- FOV (D / H / V): 74° / 64.5° / 36°
- TV Distortion: < -8%
- Mount Type: CS

Dimensions

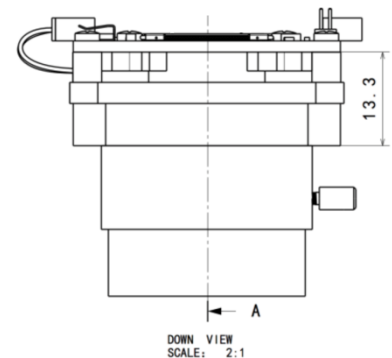
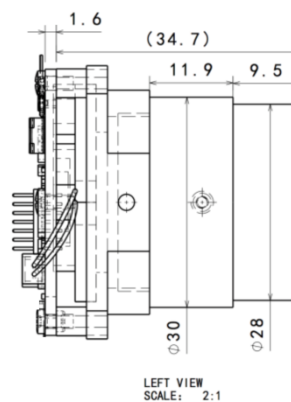
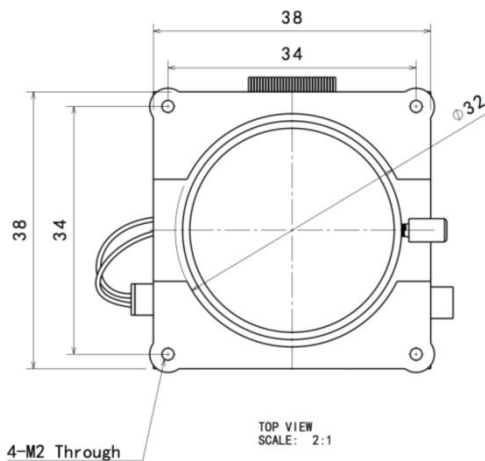

Leopard Imaging Inc.

910 Auburn Ct, Fremont, CA 94538, USA
Phone: +1-408-263-0988
Fax: +1-408-217-1960
Email: sales@leopardimaging.com
Website: www.leopardimaging.com

Interfaces

Interface J2:

- Part#: 20525-030E-02C
- Number of Positions: 30
- Pitch: 0.4 mm
- Mating I-PEX cable: FAW-1233-03 (300 mm)

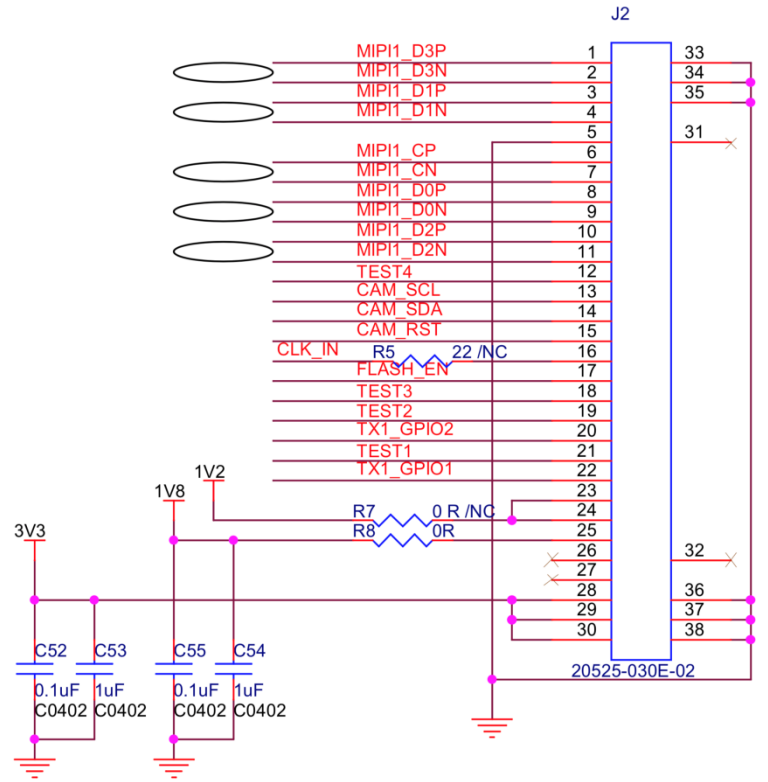

Revision History

Revision	Description	Release Date
1.0	First release.	20. Sep. 2018
1.1	Deleted info quoted from sensor spec.	26. May. 2022
1.2	Updated lens.	24. Jul. 2023



Leopard Imaging Inc.

910 Auburn Ct, Fremont, CA 94538, USA
Phone: +1-408-263-0988
Fax: +1-408-217-1960
Email: sales@leopardimaging.com
Website: www.leopardimaging.com